



PAPER ID: 10A15E



DETERMINATION THE MOST EFFICIENT TRACKING TECHNIQUE FOR THE MAXIMUM POWER POINT OF SOLAR SYSTEMS IN RAPID ENVIRONMENTAL CHANGING CONDITIONS

Mohammad Sadegh Javadi ^a, Rahil Bahrami ^{b*}

^a Department of Electrical Engineering, Shiraz Branch, Islamic Azad University, Shiraz, Iran

^b Department of Electrical Engineering, Faculty of Engineering, Science and Research Branch, Islamic Azad University, Tehran, Iran

ARTICLE INFO

Article history:

Received 20 May 2019
Received in revised form 15 July 2019
Accepted 14 August 2019
Available online 26 August 2019

Keywords:

Maximum Power Point Tracking (MPPT); Photovoltaic Panel; Perturb and Observe; Solar Cell; Zero Current Switching Converters.

ABSTRACT

Nowadays, increasing fossil fuel usage in communities has led to an unpleasant consequence. Environmental pollution is caused by unnecessary consumption, on the other hand, the reduction of resources are the most important consequences. Hence, using renewable and clean fuels like solar energy is a good replacement. In many countries, solar cells play a significant role in generating electricity, but the cost of electricity produced by them is very high due to the high cost of construction and maintenance; that is why they are less popular. Many efforts have been made in recent years, to determine the working point of solar cells which are used in any environment and at maximum power. The peak power point The point at which the cell has the highest output power is called, called the maximum power point tracking (MPPT) technique, in terms of how to set the point of reference at the maximum power point. In this thesis, some techniques for tracking the maximum power point of solar cells have been introduced; among them the performance of two hill-climbing techniques and incremental conductance in variable environmental conditions and two scenarios have been investigated.

©2019 INT TRANS J ENG MANAG SCI TECH.

1. INTRODUCTION

Today, the growth of energy consumption in modern industrialized societies has led the world to face irreversible and threatened environmental degradation, in addition to the risk of the rapid extinction of fossil fuels. Therefore, in international programs and policies, a special role has been devoted to renewable energy sources for sustainable global development [1]. The World Energy Organization has suggested that fossil fuels such as oil, coal, and gas will end in less than ten decades.

Fossil fuels contain more than 79% of primary energy consumption in the world, of which 57.7% is used in transportation. The growing demand and the community have forced politicians to seek a suitable alternative to fossil fuels [2].

Renewable energies have been much considered in recent years due to increased availability and lower costs, so that, for example, the European Union generated 12% of its electrical energy in 2010 through new energies. In our country, in this regard, the Organization of New Energy of Iran, following the policies of the Deputy Minister of Energy Affairs of the Ministry of Energy since 1995, has undertaken to address this issue in order to access the information and technologies of the world about the use of renewable energy sources, potential research and implementation of numerous projects. [3]. Renewable energies have different energy structures than conventional energy production technologies because the development process of renewable energy has high initial investment costs and the maintenance costs are low, but in the generating energy from conventional sources methods, the costs of primary investment are low. It can be expected to have different benefits to the development of renewable energy usage in the country, mainly depending on local conditions, the characteristics of alternative resources and social concerns. One of the benefits of renewable energy is increasing the security of energy supply, reducing global warming and environmental protection [1]. The exploitation of renewable energy also increases the availability of sustainable and secure energy sources for less developed regions. Tracking the maximum power point in a solar cell is very important due to the increased use of PVs in small and large networks and the maximum exploitation of solar cells. Hence, it is urgent and cost-effective to use an efficient maximum power point tracking (MPPT) technique that can track this point in any environmental conditions [4].

The purpose of this study is to determine the most efficient technique for tracking the maximum power point of solar systems' rapid environmental changing conditions.

2. BACKGROUND RESEARCH

It is really important to have a renewable energy system. Wind and sunlight energy are some of the most renewable energies. Solar energy, among other renewable energies, is a matter of great interest. Hence, the demand for solar cells to supply energy is increasing. More than 45% of future energy will be generated by solar cells [5].

The solar cell acts as a current source, which produces current as light radiates at the surface. A PV cell alone cannot produce enough power and is not used in many applications. In order to get the maximum energy from the cell, they are connected in parallel or in series. PV modules can produce output power [6].

MPPT techniques are used to find the voltage and current that maximizes the power of the PV array at a certain temperature and radiation conditions. The first MPPT techniques were introduced in the 1960s. Today, many techniques have been introduced to track the maximum power point in PV systems. These techniques include open-circuit voltage, short circuit current, hill climbing, and smart techniques. The use of hill climbing techniques, incremental conductance, and distraction and observation are more common among the many techniques available, which are used for simplicity

and convenience [7].

The drawback of the PV system is the high cost of solar cells and low economic interest. Although the price has slowed down in recent years, with the advancement in the structure and process of solar cell production, the price of electricity produced by solar arrays is still high in terms of electricity produced by fossil fuels. Therefore, the use of the PV array is extremely important at maximum power [8].

When the PV array is directly connected to the charge or used to charge the battery, the system's operating point is at the intersection of the I-V curve of the solar system and the load line. Normally, this point is not in the MPP of the PV array [9]. Installation costs in solar systems are high. In order to overcome this problem, a power converter is used with a key switch called the maximum power point tracker to maintain the point of the PV system in the MPP [10].

Numerous techniques have been developed for tracking maximum power so far. The general principles of methods can be divided into four categories: the first is the techniques that follow a basic algorithm. These types of techniques can be referred to as distraction and observation, hill climbing and increasing conduct.

The second group of techniques is based on solar cell modeling. In these techniques, solar cell modeling and the establishment of relationships in the proposed model will be predictable for solar cell properties and the system will be designed and implemented based on the model. The main problem with this type of technique is the lack of flexibility by replacing the solar cell with another cell. In a way, each implementation only has been designed for the same solar cell. In addition to the problem, finding a solar cell model and parameters before designing itself is another problem.

The third group of techniques is based on the relationship between working point and solar cell parameters. The fourth category is smart controlling techniques. In this type of technique, fuzzy logic control or fuzzy logic and artificial neural networks are used. The maximum power point control and tracker can include sensors, PWM wave generator, and MPPT implement. This section, with the MPPT control system, can be found depending on the technique available by measuring the required point-of-duty parameters, which is the maximum point of the solar cell's output power [11-13].

3. IMPLEMENTATION AND RESULT

3.1 INTRODUCING MAXIMUM SOLAR POWER POINT TRACKING TECHNIQUES

3.1.1 HILL-CLIMBING TECHNIQUE

This technique uses a change in the converter working cycle to determine the maximum power point. As shown in Figure 1, before MPP, the increase in voltage increases the power, but after MPP, we can increase the voltage by decreasing the voltage. This is the basis of the hill-climbing technique [14].

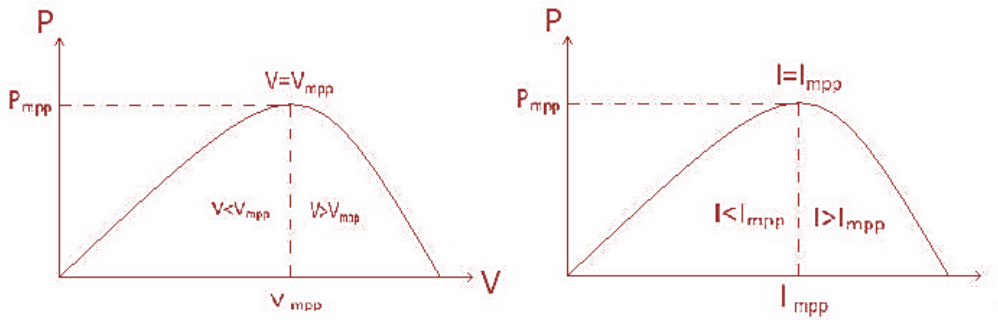

Figure 1: The hill-climbing technique chart [14].

The Flowchart of this technique is presented in Figure 2. In fact, when the condition $\frac{dP}{dD} = 0$ holds the maximum power point is tracked. The cycle of work in each sampling period is obtained by comparing the power in the present moment and power at the instant. When $dP > 0$, the working cycle must be increased to $dD > 0$. If $dP < 0$, the work cycle should be reduced to $dD < 0$ [15].

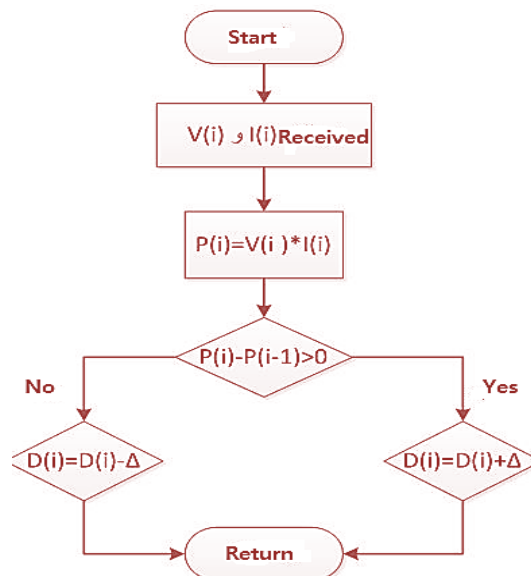

Figure 2: Flowchart of the hill-climbing technique [15]

The main problem in this technique is the relationship between the system stability in steady-state periods and the lack of rapid response to changing radiation conditions. Steady-state periods require a small change in the work cycle to prevent a high oscillation around the maximum power point, as this will reduce the energy received by the PV. On the other hand, rapid changes in radiation require a larger work cycle to track maximum power [16]. Another problem with this technique is its fluctuation around the maximum power point. Of course, this oscillation can be reduced by diminishing the range of dD variations, but it slows the process of finding MPP [17].

3.1.2 INCREMENTAL CONDUCTANCE TECHNIQUE

This technique has been used more than others among all the MPPTs techniques because it has more precision in tracing in stable conditions and has the ability to better adapt to variable weather conditions [17]. This technique uses the PV power curve to track MPP. The slope of the PV curve at the MPP moment is zero and for output voltage values it is less than the MPP voltage is positive and for output voltage values greater than the MPP voltage is negative. The derivative of the power of the

PV module is given in relation (1), and the resulting relation for the error value e is obtained from (3) [18]:

$$\frac{dP}{dV} = \frac{d(V \times I)}{dV} = I + V \frac{dI}{dV} = 0 \quad (1).$$

Also,

$$\frac{dI}{dV} + \frac{I}{V} = \frac{I(i) - I(i-1)}{V(i) - V(i-1)} + \frac{I(i)}{V(i)} = 0 \quad (2),$$

and

$$e = \frac{I(i) - I(i-1)}{V(i) - V(i-1)} + \frac{I(i)}{V(i)} \quad (3).$$

Therefore, the MPP tracking is required to follow the trend shown in Figure 3. This is done by inserting a simple separator with the e signal as the input and the coefficient of fit k . Correlation coefficient function k is adjusting the error signal e in the appropriate range before the integral compensator. The closer the point of reference to the MPP is, the smaller the error signal e , which makes tracking easy [19].

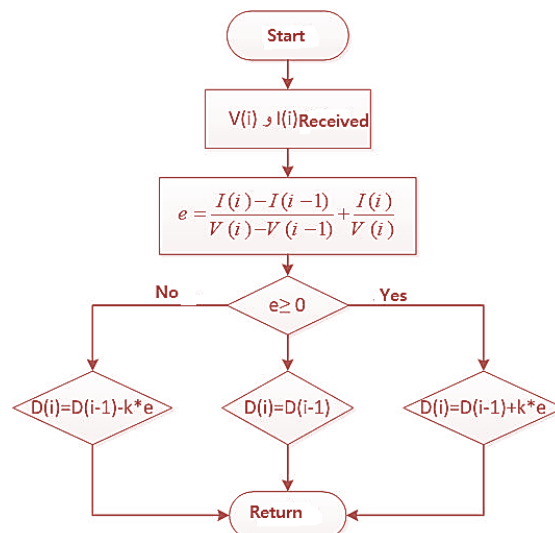

Figure 3: Flowchart of Incremental Conductance Technique [19]

3.2 MODELING OF MAXIMUM POWER POINT TRACKING TECHNIQUES IN THE SOLAR SYSTEM

In the presented models, one solar module with a maximum power of 60 watts is used as the solar system; and its voltage and current outputs will be used as inputs of the intended technique. On the other hand, the influencing factors of operation of the solar module are the temperature and solar radiation, and it is possible to examine the reactions of the techniques by applying changes to these conditions.

3.2.1 SIMULATED SOLAR SYSTEM

Figure 4 shows the solar system used in the simulations. This system includes a PV module, a

boost converter, and a battery. Radiation R shines on the module and its temperature T is measured. Simulations are made for two hill-climbing and incremental conductance techniques. The PV system consists of the following components.

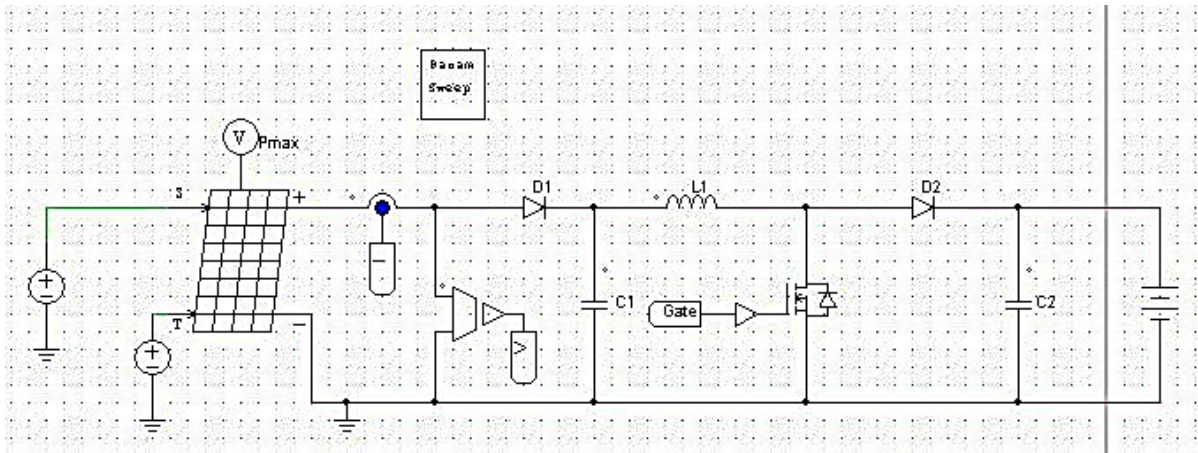

Figure 4: PV system.

The amount of solar radiation and operating temperature in the introduced system was initially considered as constant then it has been investigated by applying changes in the system response at different temperatures and radiation. The temperature has changed from 25 to 60 degrees Celsius and the radiation range from 800 to 1000 W/m^2 . The following system components are introduced:

Module PV: The used module includes 36 silicon-based polycrystalline cells. The electrical characteristics of this module are shown in Table 1.

Table 1: Electrical Specifications of the PV Module.

Max power(P_{max})	50 W
Voltage in (V_{mp}) P_{max}	17.1 V
Flow in (I_{mp}) P_{max}	3.5 A
Short circuit current (I_{sc})	3.8 A
Open circuit voltage(V_{oc})	21.1 V

DC/DC Boost Converter: Load impedance must be equal to the source impedance to have a maximum power transmission from source to load. Impedance equivalence can be achieved by adjusting the DC/DC converter's working cycle. The converter should work with the corresponding cycle of work to determine the maximum power point. The converter cycle should be adjusted with the variable operating conditions so that the maximum power is taken from the PV module. There are different architectures for the DC/DC converter, but due to the wide use and reliability of the architecture, this architecture has been used. The D_1 diode protects the PV module against the negative current. C_1 is located at the entrance of the converter to limit the components of the high-frequency harmonics.

3.3 TECHNIQUES AND SIMULATION SCENARIOS

The responsiveness has been investigated under two constant temperatures and steady-state scenarios in order to investigate the performance of the techniques. The values of temperature and radiation for all three models are considered to be of the same magnitude to facilitate the comparison; in the steady-state, the temperature is 25, 45 and 60 degrees Celsius, and in the steady-state radiation conditions they are 900, 950, and 1000 W/m^2 .

3.3.1 HILL CLIMBING TECHNIQUE

Simplicity is the key advantage of this technique. The main problem with this technique is the stability of the system under constant radiation conditions and the lack of rapid response to rapid changes in radiation. Stationary radiation requires a small cycle of work to prevent high power fluctuations around the maximum power point, which reduces the amount of energy received by the PV. On the other hand, rapid changes in radiation need more work cycles to quickly track the maximum power point. An illustration of the simulated HC technique is shown in Figure 5.

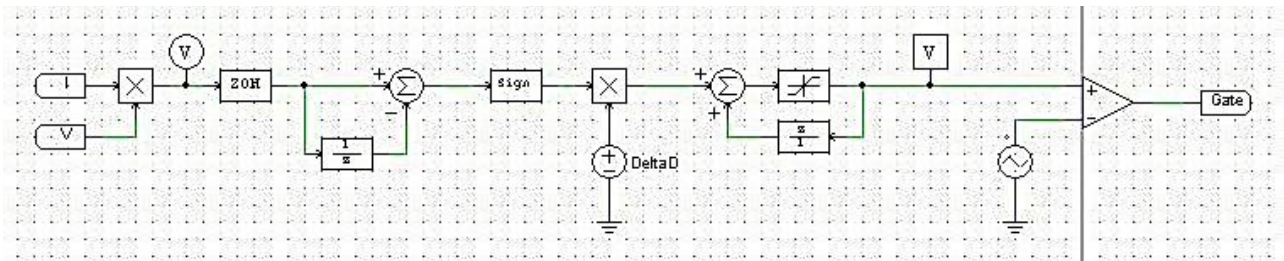

Figure 5: Slope Technique in Simulation.

3.3.2 INCREMENTAL CONDUCTANCE TECHNIQUE

The incremental conductance technique is very much used compared to all the MPPT techniques due to the high accuracy of tracing in stable conditions and good adaptation to atmospheric conditions. The disadvantages of this technique can be high operating costs. The following is an overview of the incremental conductance technique. In Figure 6, this technique is implemented according to the flowchart process.

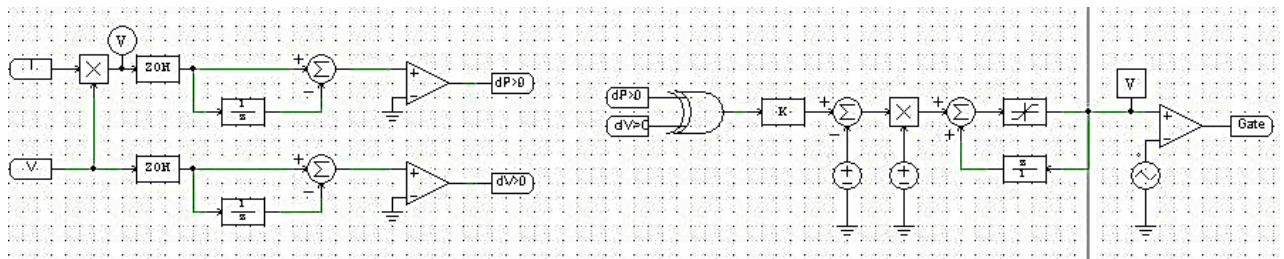

Figure 6: Incremental conductance technique 1 (in accordance with flowchart) in simulation.

3.4 SIMULATION RESULTS

In this section, the images of response techniques are presented in both scenarios. It should be noted that in addition to the sustained response, the dynamic response of these two techniques is also presented.

3.4.1 THE FIRST SCENARIO: A CONSTANT RADIATION WITH VARIED TEMPERATURES

In this scenario, radiation is considered to be 800W/m^2 , and the temperatures are 25, 45 and 60 degrees Celsius respectively.

Table 2: Constant radiation with varied temperatures.

Color	Work cycle rate	Color	Work cycle rate
Red	2%	Purple	8%
Dark blue	4%	Orange	10%
Green	6%	Pale blue	P

From Table 2, the speed of tracing decreases for the hill-climbing technique with increasing

temperature, and this is independent of the amount of work cycle. For example, in a working cycle of 2%, the start time of the track at 25°C is 0.02 seconds, and this value reaches 0.05 and 0.08 seconds at 45°C and 60°C. This has also been the case for other values of the work cycle. On the other hand, the dynamic response is clear. This technique has a lot of fluctuations around the point of work, which has previously been cited as one of the disadvantages of this technique. The amount of fluctuations increases with the increasing working cycle, but the temperature increase increases the number of oscillations.

3.4.2 THE SECOND SCENARIO: VARIED RADIATION WITH A CONSTANT TEMPERATURE

In this scenario, the temperature is 25°C and the radiations are 900, 950, and 1000 W/m², respectively.

Table 3: Constant temperature with varied radiations.

Color	Work cycle rate	Color	Work cycle rate
Red	2%	Purple	8%
dark blue	4%	Orange	10%
Green	6%	Pale blue	P

According to Table 3, there is no change in the radiation pattern at the start of tracing for the hill-climbing technique, and this is independent of the amount of work cycle. For example, in a working cycle of 2%, the start time of the detection in the radiation is 900 times 0.02 seconds, and this value reaches 0.02 seconds for the radiation of 950 and 1000 W/m². This has also been the case for other values of the work cycle.

4. DISCUSSION

4.1 DISCUSSION THE RESULTS OF SIMULATION TECHNIQUES

Maximum power point tracking techniques are put in ambient conditions such as temperature and radiation variations, but their performance results have been examined only in the mode of the change of a factor due to the complexity of their complexity, that is why only one factor has been investigated at any one time. Also, sampling frequencies are considered low and the work cycle is updated at the same time in order to emphasize the accuracy of the output results. The mentioned techniques are compared in terms of response time (tracking speed) and dynamic response. The result is drawn with changes in the various work cycles, and for more clarity at the end, all the graphs obtained in each cycle are drawn together in order to make it easier to compare the time and accuracy of the responses between simulated different techniques. At first, the results of each technique in the first and second scenarios are examined separately, then the overall results are compared with each other.

4.2 THE FIRST SCENARIO OF CONSTANT RADIATION WITH VARIED TEMPERATURES

As can be readily seen, the speed of tracing decreases for the hill-climbing technique with increasing temperature, and this is independent of the amount of work cycle. For example, in a working cycle of 2%, the start time of the track at 25°C is 0.02 seconds, and this value reaches 0.05 and 0.08 seconds at 45°C and 60°C. This has also been the case for other values of the work cycle. On the other hand, the dynamic response is clear. This technique has a lot of fluctuations around the point

of work, which has previously been cited as one of the disadvantages of this technique. The amount of fluctuations increases with the increasing working cycle, but the temperature increase increases the number of oscillations.

The low performance in high temperatures is due to the poor performance of the solar cell assembly. Because at high temperatures the cell flow is significantly increased, but the voltage decreases linearly, which ultimately reduces the total gain of the set. This is the case for the other two techniques in the first scenario.

As we have seen, the incremental conductance technique decreases with tracking speed with increasing temperature, and this is independent of the amount of work cycle. In a working cycle of 2%, for example, the start time of the track at 25°C is 0.04 seconds, and this value reaches 0.77 and 0.1 seconds at 45°C and 60°C. This has also been the case for other values of the work cycle.

On the other hand, it is clear from the dynamic response that this technique also has many fluctuations around the point of work, which can be cited as one of the disadvantages of an incremental conductance technique, but the simplicity of the execution partly compensates this defect. The amount of fluctuations increases with the increasing working cycle, but the temperature increase increases the number of oscillations.

Comparing the two techniques shows that the response time in the hill-climbing technique is lower, but the incremental conductance technique is faster than the hill technique to the desired work point. The oscillation rate in the observation technique is lower, but as indicated, this technique does not function well at the variable temperature and makes the system unstable. Therefore, in steady-state and variable temperature conditions, if the response speed is considered, the hill-climbing technique is appropriate and if the responding time of the working point is considered, then the incremental conductance technique is appropriate.

4.3 THE SECOND SCENARIO OF VARIED RADIATIONS WITH A CONSTANT TEMPERATURE

As observed, there is no change in the radiation pattern at the start of tracing for the hill-climbing technique, and this is independent of the amount of work cycle. For example, in a working cycle of 2%, the start time of the detection in the radiation is 900 times 0.02 seconds, and this value reaches 0.02 seconds for the radiation of 950 and 1000 W/m². This has also been the case for other values of the work cycle.

On the other hand, the dynamic response is clear. This technique has many fluctuations around the point of operation. The amount of fluctuations increases with the increase of the working cycle, but the increase in temperature reduces the number of oscillations slightly.

The performance weakness in high radiation is due to the poor performance of the solar cell set. Because the high radiation influences the p-n bonds in the semiconductors, which ultimately reduces the overall gain of the set.

As seen, the incremental conductance technique does not show a change in radiation at the start of tracing, and this is independent of the amount of work cycle. For example, in a working cycle of

2%, the start time of the tracking in the radiation is 900 times 0.04 seconds, and this value reaches 0.04 seconds for radiation of 950 and 1000 W/m². This has also been the case for other values of the work cycle.

On the other hand, the dynamic response is clear. This technique has many fluctuations around the working point. The amount of oscillation increases with increasing work cycle, but the temperature increase significantly reduces the number of oscillations.

5. CONCLUSION

Comparing the two techniques shows that the responding time in the hill-climbing technique is less, but the incremental conductance technique is faster than the desired working point. The amount of oscillation in the observation technique is lower, but the time to reach the optimal point in this technique is very high. Therefore, in variable and steady-state modes, if the time for commencement of accountability is considered, the hill-climbing technique is faster, but if the speed of reaching the work point is considered, then the incremental conductance technique is appropriate.

6. REFERENCES

- [1] Bonfiglio, A., et al. (2014). "Optimal Control and Operation of Grid-Connected Photovoltaic Production Units for Voltage Support in Medium-Voltage Networks." *IEEE Transactions on Sustainable Energy* 5(1): 254-263.
- [2] SANA. (2019). New Energy Organization (SANA). <http://www.suna.org.ir>
- [3] Rezk, H. and A. M. Eltamaly (2015). "A comprehensive comparison of different MPPT techniques for photovoltaic systems." *Solar Energy* 112: 1-11
- [4] Murtaza, A. F., et al. (2013). Comparative analysis of maximum power point tracking techniques for PV applications. Multi-Topic Conference (INMIC), 2013 16th International
- [5] Romero-Cadaval, E., et al. (2013). "Grid-Connected Photovoltaic Generation Plants: Components and Operation." *IEEE Industrial Electronics Magazine* 7(3): 6-20
- [6] Reza Reisi, A., et al. (2013). "Classification and comparison of maximum power point tracking techniques for the photovoltaic system: A review." *Renewable and Sustainable Energy Reviews* 19: 433-443
- [7] Noorollahi, Imaneh, and Majid Ehteshami, 2016, Solar Energy Production Capacity in Iran, First National Conference on Crisis Management, Safety, Health, Environment and Sustainable Development, Tehran, Mehr Arvand Institute of Higher Education, Center for Achieving Sustainable Development
- [8] Shah Hoseini, Ehsan and Behzad Karimi, 2016, Photovoltaic Systems and Applications, International Conference on Civil Engineering, Architecture and Urban Landscape, Turkey - Istanbul University, Permanent Secretariat, Istanbul University
- [9] Hassanzadeh, Farnaz; Amir Khanjanzadeh and Shahriar Temmandani, 2016; Efficiency Optimization Methods at Solar Power Plants; 3rd International Conference on Science and Engineering; Istanbul; Turkey; Institute for Managers of the Vida Capital Ideas
- [10] Bonfiglio, A., et al. (2014). "Optimal Control and Operation of Grid-Connected Photovoltaic Production Units for Voltage Support in Medium-Voltage Networks." *IEEE Transactions on Sustainable Energy* 5(1): 254-263

- [11] Brito, M. A. G. d., et al. (2013). "Evaluation of the Main MPPT Techniques for Photovoltaic Applications." IEEE Transactions on Industrial Electronics 60(3): 1156-1167
- [12] Faranda, R., et al. (2008). MPPT techniques for PV Systems: Energetic and cost comparison. Power and Energy Society General Meeting - Conversion and Delivery of Electrical Energy in the 21st Century, 2008 IEEE
- [13] Subudhi, B. and R. Pradhan (2013). "A Comparative Study on Maximum Power Point Tracking Techniques for Photovoltaic Power Systems." IEEE Transactions on Sustainable Energy 4(1): 89-98
- [14] Dash, S. K., et al. (2014). Comparative analysis of maximum power point (MPP) tracking techniques for solar PV application using MATLAB Simulink. International Conference on Recent Advances and Innovations in Engineering (ICRAIE-2014)
- [15] Mohanty, P., et al. (2014). "MATLAB based modeling to study the performance of different MPPT techniques used for a solar PV system under various operating conditions." Renewable and Sustainable Energy Reviews 38: 581-593
- [16] Raj, J. S. C. M., and A. E. Jeyakumar (2014). "A Novel Maximum Power Point Tracking Technique for Photovoltaic Module Based on Power Plane Analysis of I-V Characteristics." IEEE Transactions on Industrial Electronics 61(9): 4734-4745
- [17] Banu, I. V., et al. (2013). Comparative analysis of the perturb-and-observe and incremental conductance MPPT methods. 2013 8Th International Symposium on advanced topics in electrical engineering (ATEE)
- [18] Sheraz, M. and M. A. Abido (2012). An efficient MPPT controller using differential evolution and neural network. 2012 IEEE International Conference on Power and Energy (PECon)
- [19] Sharma, P., et al. (2014). "A Novel Approach for Maximum Power Tracking from Curved Thin-Film Solar Photovoltaic Arrays Under Changing Environmental Conditions." IEEE Transactions on Industry Applications 50(6): 4142-4151.



Dr. Mohammad Sadegh Javadi is an Assistant Professor at Department of Electrical Engineering, Shiraz Branch, Islamic Azad University, Shiraz, Iran. His research encompasses Renewable Energy Technologies, Power Systems Analysis, Power Systems Simulation, Distributed Generation.



Rahil Bahrami is a graduate student at Department of Electrical Engineering, Faculty of Engineering, Science and Research Branch, Islamic Azad University, Tehran, Iran.