



Paper ID: 10A09F



## A JUSTIFIED PLAN GRAPHICAL MATHEMATICAL ANALYSIS OF TRADITIONAL HOUSES IN MODERATE AND HUMID CLIMATE OF IRAN

Atikeh Mohammadi Nasab<sup>a</sup>, Peiman Pilechiha<sup>a\*</sup>, Mina Hajian<sup>b</sup>

<sup>a</sup> Department of Architecture, Kowsar Institute of Higher Education, IRAN

<sup>b</sup> Architecture Department at Bu-Ali Sina University, IRAN.

### ARTICLE INFO

#### Article history:

Received 12 March 2019

Received in revised form 24 June 2019

Accepted 02 July 2019

Available online 12 July 2019

#### Keywords:

Housing spatial configuration; Housing space parameters; Convex map; Integration value; Justified plan graph; Control value; Traditional house; Space syntax.

### ABSTRACT

Today, the architecture of Iranian houses faces a historic break from its own identity background, and all attempts to produce Iranian architecture have been reduced to formal imitations. This paper examines the mathematical-graphical model for analyzing the spatial configuration of traditional houses in the moderate and humid climate of Iran to response this question which how a model for the design of today's houses in northern Iran can be extracted from past monuments of this land. In this research, six of the historic houses in the north of the country were randomly selected, all of which are similar in size and belong to a 100-year time interval. In these cases, after the preparing convex map, their justified plan graph (JPG) is plotted and readout. In fact, in each house, architectural plan, convex map, JPG, and mathematical calculations for control value, integration value and other space parameters are done and their charts are mapped and the data of each of the six houses are compared. By comparing the justified plan graph of the houses as well as the comparison of control value and integration value, the spaces each house has a similar pattern in all of them that is close to each other in terms of mean depth, control value, and integration value of the spaces. In all cases, the courtyard has the most integration value, and the closet, the storage, and the terrace have the least integration value and control value. Finally, by analyzing the JPG, the computational data is the same pattern in all the cases that can be considered as the archetype of traditional houses in northern Iran. An ancient pattern that can be used in the identity spatial organization of today's generations of houses in northern Iran.

© 2019 INT TRANS J ENG MANAG SCI TECH.

## 1. INTRODUCTION

Space syntax is a method dealing with space prioritization in architecture. This method has made the architectures' attitude in different areas unique, based on the desired location or climate and folk

culture. So far, investigating the architecture styles and space syntax was mainly based on analyzing a picture of the desired building. Nowadays, given the advancement of science, the Justified Plan Graph (JPG) method and mathematical calculations are significantly improving. This is important as it provides the architectures with a scientific method to investigate the space hierarchy attitude in a given area or climate in a scientific framework (Nakhaee and Arab Nasrabadi, 2019).

Given the fact that the JPG is rarely used in the design and space prioritization of Iranian architectures, this study presents a mathematical graphical model for space syntax analysis of six traditional houses in the moderate and humid climate of the northern part of Iran, and suggests a simple old statistical pattern based on different samples in the genotype.

## 2. RESEARCH METHODOLOGY

Justified plan graph is a method for scientific investigation of the space syntax attitude in a graphical and mathematical framework. In fact, this method deals with the space hierarchy and doesn't consider the size and dimensions of the spaces (Steadman, 1983; Ostwald, 2011; Modaresi and Kazemi, 2019).

In order to mathematically analyze the justified plan graph, the architectural plan of the desired building is studied in the first step. Then, a convex map of the building is provided using an architectural plan (Lee et al., 2018; Alizadeh and Lahiji, 2018). This map is, in fact, a perspective of the top view of the building, showing the connection between the building spaces, namely the doors, stairs, and entrances. This connection is shown by a double-sided arrow. The justified plan graph of a building will be prepared after specifying its spatial connection as a convex map. To prepare the justified plan graph, first, one space is considered as the basis, shown by a crossover circle. Then, the building spaces are leveled relative to the base space, so that the entrance is considered as level 0; the places directly in connection with the entrance are considered as level 1 and the connection is shown by a line. Dash lines are used for leveling, and spatial connections are represented by bold lines. The connection between the stairs is shown by a diagonal line on the mainline (Ostwald, 2011). Figure (1) shows a simple justified plan graph.

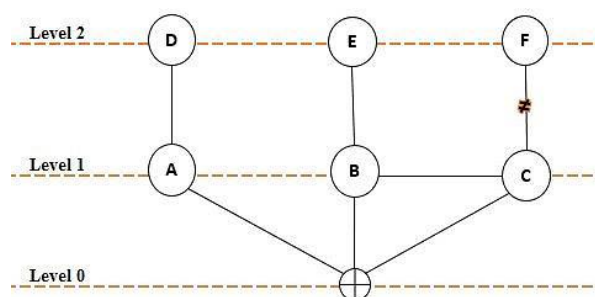

**Figure 1:** A sample justified plan graph (JPG).

As shown in Figure (1), the building entrance, considered as the base, is embedded in the level 0 by a crossover circle. The spaces A, B, and C, which are directly connected to the entrance are embedded on level 1. The spaces B and C are connected to each other and so linked by a continuous line. The spaces D, E, and F are also connected to the spaces A, B, and C, respectively. It should be noted that the space C is connected to the space F via the stairs, shown by a crossover line on the mainline.

After preparing the justified plan graph, the mathematical analysis including 8 steps would be possible.

**Step 1:** The number of nodes or spaces are counted in this step, shown by letter  $K$  (Ostwald, 2011). The number of spaces in the justified plan graph shown in Figure (1) is 7.

**Step 2:** The total depth is calculated in this step, represented by  $TD$ . To calculate the total depth, the level number is multiplied by the number of spaces in that level and the results of all layers are summed up. Equation (1) shows the formula to calculate the total depth (Ostwald, 2011).

$$TD = (0 \times n_x) + (1 \times n_x) + (2 \times n_x) + \dots + (X \times n_x) \quad (1)$$

where  $n_x$  is the number of spaces in a given level. The total depth of the entrance space of the justified plan graph, shown in Figure (1), is calculated as  $TD = (0 \times 1) + (1 \times 3) + (2 \times 3) = 9$ .

Another method to calculate the total depth, considering Figure (1) as an example, is to count the number of node lines or spaces ending in the entrance, for example, and sum them up together. In this example, the space A, B, C, D, E, and F are linked to the entrance by 1, 1, 1, 2, 2, and 2 lines, respectively, the sum of which is 9 lines, i.e., the total depth of the spaces relative to the entrance.

**Step 3:** The mean depth is calculated in this step, shown by  $MD$ . In fact, the mean depth implies the order of the depth of a given space relative to the mean depth. If the mean depth of space is greater than the mean depth, it has less access to the building entrance and is located in a farther location. Equation below shows how to calculate the mean depth (Ostwald, 2011).

$$MD = \frac{TD}{(K-1)} \quad (2)$$

It is clear from Equation (2) that the mean depth is calculated by dividing the total depth over the total number of the spaces minus 1. The mean depth of the entrance space of the justified plan graph, shown in Figure (1) is  $MD = \frac{9}{(7-1)} = 1.5$ .

**Step 4:** The relative asymmetry is calculated in this step, shown by  $RA$ . The relative asymmetry is, in fact, the normal state of the relative depth, so that it gives a method for comparison with other buildings having different spaces. Equation (3) shows the formula to calculate relative asymmetry (Ostwald, 2011)

$$RA = \frac{2(MD-1)}{(K-2)} \quad (3),$$

where  $MD$  is the mean depth and  $K$  is the number of spaces in a given building.

The relative asymmetry of the entrance space of the justified plan graph in Figure (1) is  $RA = \frac{2(1.5-1)}{(7-2)} = 0.2$ . The relative asymmetry is in the range of (0,1). The closer the relative asymmetry to 0, the more symmetric the structure of the space, while the closer the relative asymmetry to 1, the more linear the structure of the space. Since the relative asymmetry in the justified plan graph of Figure 1 is 0.2, the structure of its spaces is more symmetrical.

**Step 5:** the integration value, shown by  $i$ , is calculated in this step, which is the inverse of the relative asymmetry. Equation (4) shows how to calculate the integration value.

$$i = \frac{1}{RA} \quad (4).$$

where  $RA$  is the relative asymmetry. The integration value for the justified plan graph of Figure 1 is  $i = \frac{1}{0.2} = 5$ .

**Step 6:** So far, all the calculations were done for the entrance space. In this step, all previous calculations are done for all other spaces. To do so, a table is created in the form of a square matrix, the horizontal and vertical elements of which are the desired spaces. The calculations related to every single space is written in the corresponding cell, called the table of integration value calculations (Ostwald, 2011).

**Step 7:** The control value calculations are conducted on this step, shown by CV. Control value shows the extent of spatial impact in a plan. To calculate the control value in each space, a table is created in the form of a matrix, the horizontal and vertical elements of which represent the spaces. Then, the direct connection between the spaces is written in the corresponding cells, so that the numbers 1 and 0 imply connection and no connection, respectively. The values in each row are summed up together, shown by  $N_{cn}$ . Then,  $C_{ve}$  is calculated, which is the inverse of  $N_{cn}$ . The control value of every single space is the sum of  $C_{ve}$ s connected to it. The table obtained this way is called the control value table (Ostwald, 2011).

**Step 8:** The unrelativised difference factor is calculated in this step, shown by letter H. The unrelativised difference factor is, in fact, a measure to distinguish the spaces from each other. It is a value in the range of (0,1). The closer this factor to 0, the more different the spaces, while the closer the unrelativised difference factor to 1, the more similar the spatial structures together. To calculate the unrelativised difference factor in a plan, the minimum, mean, and maximum relative asymmetry values are first extracted from the integration value table. Then, the unrelativised difference factor is calculated according to equation (5) (Ostwald, 2011).

$$H = -\sum \left[ \frac{a}{t} \ln \left( \frac{a}{t} \right) \right] + \left[ \frac{b}{t} \ln \left( \frac{b}{t} \right) \right] + \left[ \frac{c}{t} \ln \left( \frac{c}{t} \right) \right] \quad (5)$$

where  $a$  is the maximum relative asymmetry,  $b$  is the mean relative asymmetry,  $c$  is the minimum relative asymmetry, and  $t$  is the sum of  $a$ ,  $b$ , and  $c$ .

After calculating the unrelativised difference factor, it should be turned into a relative form, so that comparing the plans would be feasible. The relative difference factor, represented by  $H^*$ , is calculated as (Ostwald, 2011)

$$H^* = \frac{(H - \ln 2)}{(\ln 3 - \ln 2)} \quad (6)$$

### 3. FINDING

In this section, the results of the review of the justified plan graph of six traditional houses in northern Iran selected from the houses registered at the Cultural Heritage Organization, all with the same size, are presented. Table 1 interprets the abbreviations used in each map.

**Table 1:** Room abbreviations used in the JPG

A	Entrance	G	Main Room	M	Distribution Space
B	Courtyard	H	Bath	O	Kitchen
C	Vestibule	I	5 Door Room	O1	Toilet
D	Porch	J	Store	Q	Servant Room
E	Room	K	3 Door Room	R	Storage
F	Veranda	L	Lobby	U	Engine House

### 3.1 SHAFABI HOUSE (House 1)

Shafahi house is related to the Qajar period and is located in the Amol City, central part, Ayatollah Javadi Ave., Niaki old texture of the neighborhood, with an approximate area of 1000 m<sup>2</sup>. This building was registered as a national monument of Iran on March 4, 2006, with the registration no.17802 (Ministry of Housing and Urban Development of Iran, 1993). Figure 2 depicts the architectural plan of this house. Figure 3 shows a constructed convex map. Figure 4 illustrates the justified plan graph of House 1. Table 2 also shows a summary of the performed calculations related to this house.

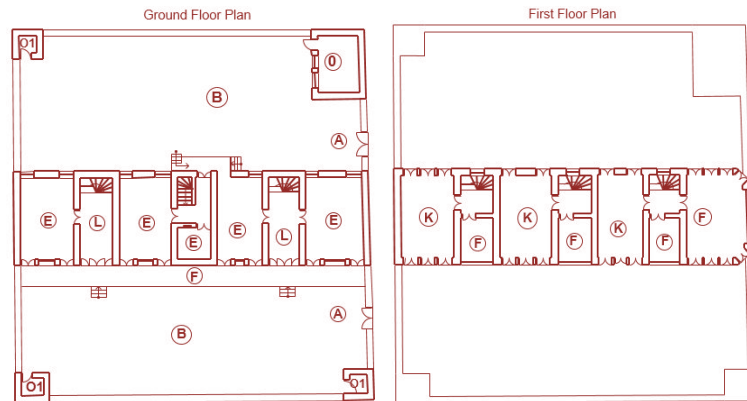

**Figure 2:** Architectural plan for the Shafahi House (House 1) (Ministry of Housing and Urban Development of Iran, 1993)

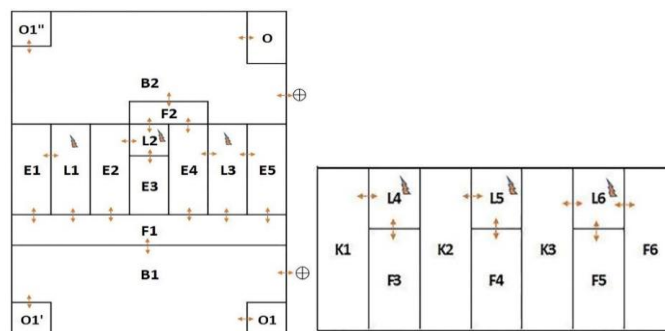

**Figure 3:** Convex Map for the Shafahi House (House 1)

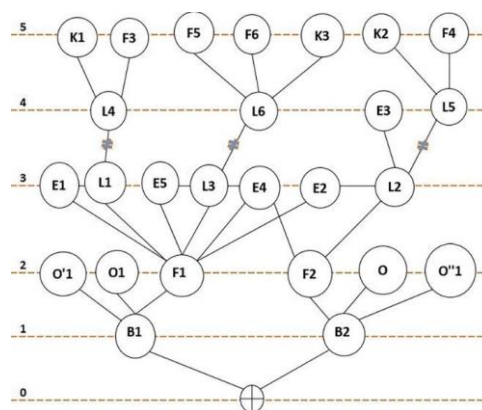

**Figure 4:** JPG with the exterior as the carrier for the Shafahi house (House 1).



**Table 2:** Data summary for the Shafahi House (House 1)

#	0	1	2	3	4	5	6	7	8	9	10	11	12	13	14	15
(V $\alpha$ )	$\oplus$	B1	B2	O'1	O1	F1	F2	O	O'1	E1	L1	E5	L3	E4	E2	L2
TDn	6	74	87	99	99	61	77	112	112	82	79	81	72	71	72	79
MDn	3.31	2.85	3.35	3.81	3.81	2.35	2.96	4.31	4.31	3.15	3.04	3.12	2.77	2.73	2.77	3.04
RA	0.18	0.15	0.19	0.22	0.22	0.11	0.16	0.26	0.26	0.17	0.16	0.17	0.14	0.14	0.14	0.16
i	5.42	6.77	5.33	4.45	4.45	9.29	6.37	3.78	3.78	5.80	6.13	5.91	7.07	7.22	7.07	6.13
CV	0.50	2.64	2.83	0.25	0.25	2.75	0.83	0.25	0.25	0.48	0.98	0.48	0.98	0.81	0.39	2.17

#	16	17	18	19	20	21	22	23	24	25	26	Mean	Min	Max
(V $\alpha$ )	L4	L6	E3	L5	K1	F3	F5	F6	K3	K2	F4			
TDn	100	91	105	100	125	125	117	117	117	126	126	93	6	126
MDn	3.85	3.50	4.04	3.85	4.81	4.81	4.50	4.50	4.50	4.85	4.85	3.69	2.35	4.85
RA	0.23	0.20	0.24	0.23	0.30	0.30	0.28	0.28	0.28	0.31	0.31	0.22	0.11	0.31
i	4.39	5.00	4.11	4.39	3.28	3.28	3.57	3.57	3.57	3.25	3.25	5.06	3.25	9.29
CV	2.33	3.33	0.25	2.25	0.33	0.33	0.25	0.25	0.25	0.33	0.33	1.00	0.25	3.33

H	1.016
H*	0.797

### 3.1 DAROOEI HOUSE (House 2)

Darooei House is a collection of monuments of the Qajar period (1893) in Gorgan City, in the Baghshah neighborhood, with an approximate area of 1000 m<sup>2</sup>, which was nationally registered in 2001 and sold to a municipality of Gorgan (Ministry of Housing and Urban Development of Iran, 1993). In Figure 5, the architectural plan of this house is depicted. Figure 6 shows the constructed convex map. Figure 7 illustrates the justified plan graph of house 2. Table 3 also shows a summary of the performed calculations related to this house.

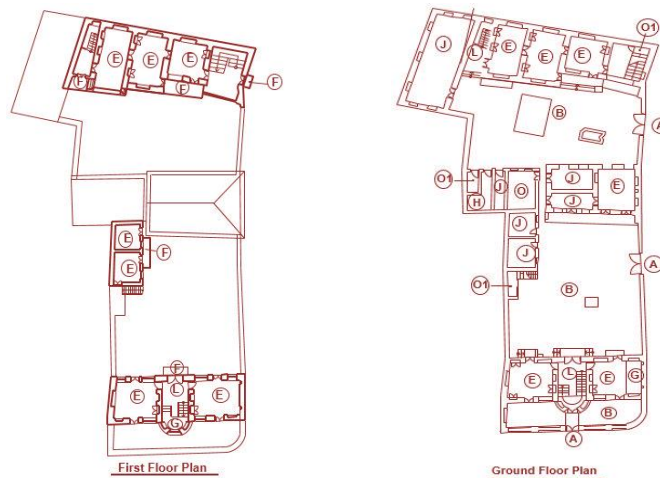

**Figure 5:** Architectural plan for the Darooei House (House 2) (Ministry of Housing and Urban Development of Iran, 1993)

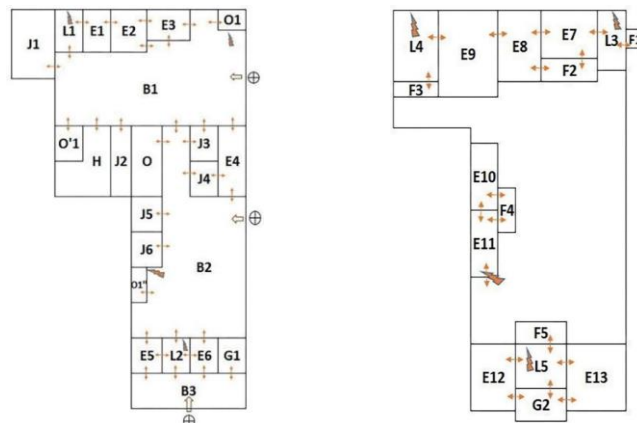

**Figure 6:** Convex Map for the Darooei house (House 2).

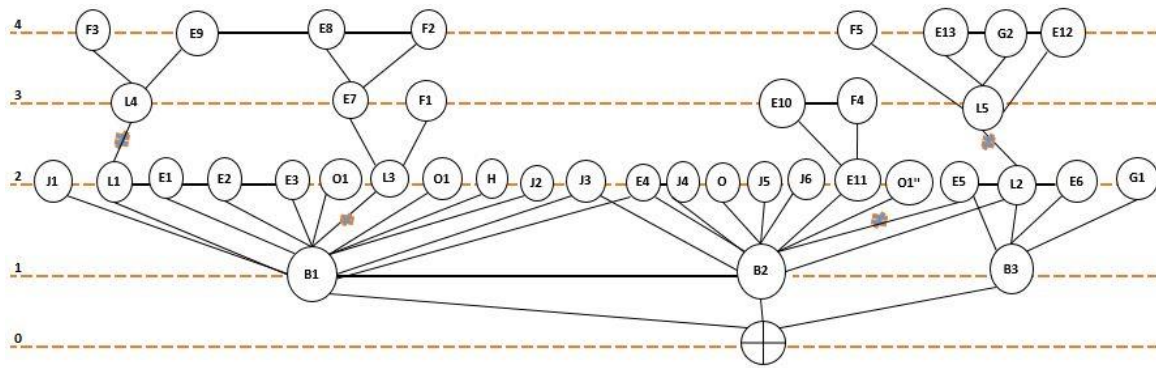

**Figure7:** JPG, with the exterior as the carrier, for the Darooei House (House 2)

**Table 3:** Data summary for the Darooei House (House 2).

#	0	1	2	3	4	5	6	7	8	9	10	11	12	13	14
(V $\alpha$ )	$\oplus$	B1	B2	B3	J1	L1	E1	E2	E3	O1	L3	O1'	H	J2	J3
TDn	97	82	82	134	121	113	116	119	120	121	113	121	121	121	111
MDn	2.55	2.16	2.16	3.53	3.18	2.97	3.05	3.13	3.16	3.18	2.97	3.18	3.18	3.18	2.92
RA	0.08	0.06	0.06	0.14	0.12	0.11	0.11	0.12	0.12	0.12	0.11	0.12	0.12	0.12	0.10
i	11.92	15.98	15.98	7.32	8.47	9.37	9.01	8.68	8.57	8.47	9.37	8.47	8.47	8.47	9.63
CV	0.35	8.08	6.27	2.37	0.07	0.74	0.74	0.90	0.40	0.07	1.40	0.07	0.07	0.07	0.15

#	15	16	17	18	19	20	21	22	23	24	25	26	27	28	29
(V $\alpha$ )	E4	J4	O	J5	J6	E11	O1''	E5	L2	E6	G1	L4	E7	F1	E10
TDn	101	120	120	121	120	117	120	110	104	140	174	143	144	151	153
MDn	2.66	3.16	3.16	3.18	3.16	3.08	3.16	2.89	2.74	3.68	4.58	3.76	3.79	3.97	4.03
RA	0.09	0.12	0.12	0.12	0.12	0.11	0.12	0.10	0.09	0.15	0.19	0.15	0.15	0.16	0.16
i	11.16	8.57	8.57	8.47	8.57	8.90	8.57	9.76	10.65	6.89	5.17	6.70	6.63	6.22	6.11
CV	0.65	0.42	0.08	0.08	0.08	1.08	0.08	0.48	1.32	0.40	0.20	1.83	1.17	0.33	0.83

#	30	31	32	33	34	35	36	37	38	39	Mean	Min	Max	
(V $\alpha$ )	F4	L5	F3	E9	E8	F2	F5	E13	G2	E12				
TDn	154	135	181	173	172	176	171	170	169	171	132.55	82	181	
MDn	4.05	3.55	4.76	4.55	4.53	4.63	4.50	4.47	4.45	4.50	3.49	2.16	4.76	
RA	0.17	0.14	0.20	0.19	0.19	0.20	0.19	0.19	0.19	0.19	0.13	0.06	0.20	
i	6.06	7.25	4.92	5.21	5.25	5.09	5.29	5.33	5.37	5.29	8.10	4.92	15.98	
CV	0.70	2.53	0.33	0.67	1.83	0.67	0.20	0.53	1.20	0.53	1.00	0.07	8.08	
H												0.996		
H*												0.747		

### 3.2 KASHANI HOUSE (House 3)

Kashani house is one of the monuments of Babol City in the Qajar period (1868) with an approximate area of 800 m<sup>2</sup> in the Ojagh Ben neighborhood (Ministry of Housing and Urban Development of Iran, 1993). In Figure 8, the architecture plan of this house is depicted. Figure9 shows the constructed convex map. Figure10 illustrates the justified plan graph of house 3. Table 4 also shows a summary of the performed calculations related to this house.

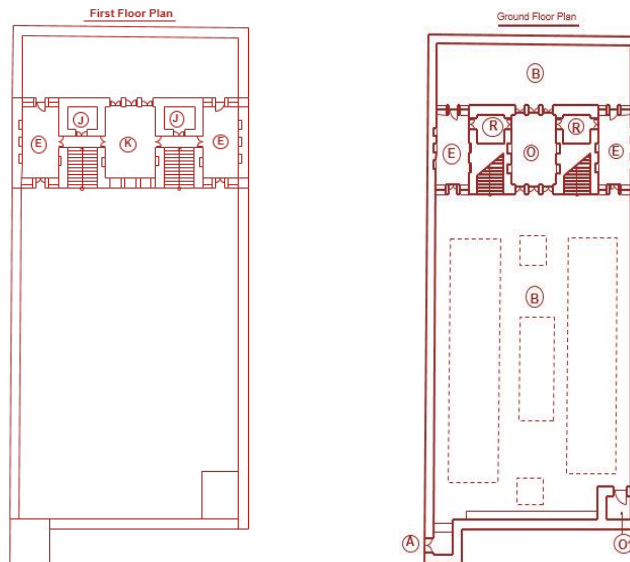

**Figure 8:** Architectural plan for the Kashani House (House 3) (Ministry of Housing and Urban Development of Iran, 1993)

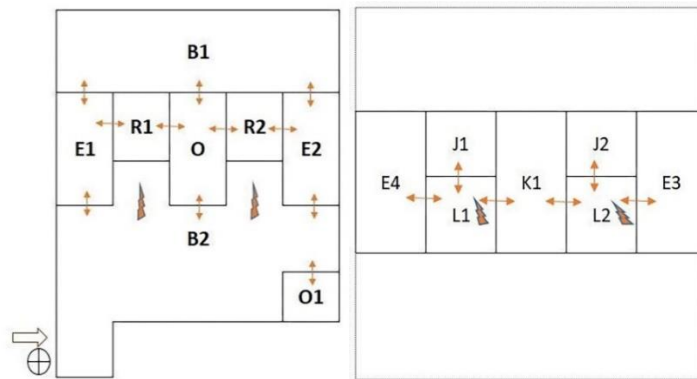

**Figure 9:** Convex Map for the Kashani house (House 3)

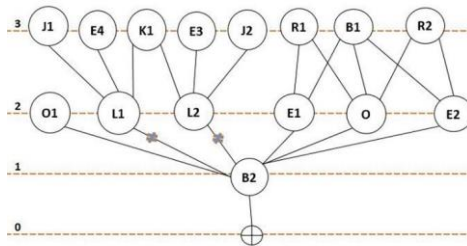

**Figure 10:** JPG, with the exterior as the carrier, for the Kashani house (House 3)

**Table 4:** Data summary for the Kashani House (House 3)

$\neq$	0	1	2	3	4	5	6	7	8	9	10	11	12	13	14	15	Mean	Min	Max
$(V\alpha)$	$\oplus$	B2	O1	L1	L2	E1	O	E2	J1	E4	K1	E3	J2	R1	B1	R2			
TDn	37	23	37	31	31	33	31	33	45	45	39	45	45	43	41	43	37.63	23	45
MDn	2.47	1.53	2.47	2.07	2.07	2.20	2.07	2.20	3.00	3.00	2.60	3.00	3.00	2.87	2.73	2.87	2.51	1.53	3.00
RA	0.21	0.08	0.21	0.15	0.15	0.17	0.15	0.17	0.29	0.29	0.23	0.29	0.29	0.27	0.25	0.27	0.22	0.08	0.29
i	4.77	13.13	4.77	6.56	6.56	5.83	6.56	5.83	3.50	3.50	4.38	3.50	3.50	3.75	4.04	3.75	5.25	3.50	13.13
CV	0.14	3.41	0.14	2.64	2.64	0.97	1.47	0.97	0.25	0.25	0.50	0.25	0.25	0.58	0.91	0.58	1.00	0.14	3.41
H																0.987			
H*																0.724			

### 3.3 GHADIRI HOUSE (House 4)

Ghadiri house is one of the monuments Pahlavi period in Rasht City, Sabzeh Meydan



neighborhood, with an approximate area of 800 m<sup>2</sup> (Ministry of Housing and Urban Development of Iran, 1993). In Figure 11, the architectural plan of this house is depicted. Figure 12 shows the constructed convex map. Figure 13 illustrates the justified plan graph of house 4. Table 5 also shows a summary of the performed calculations related to this house.

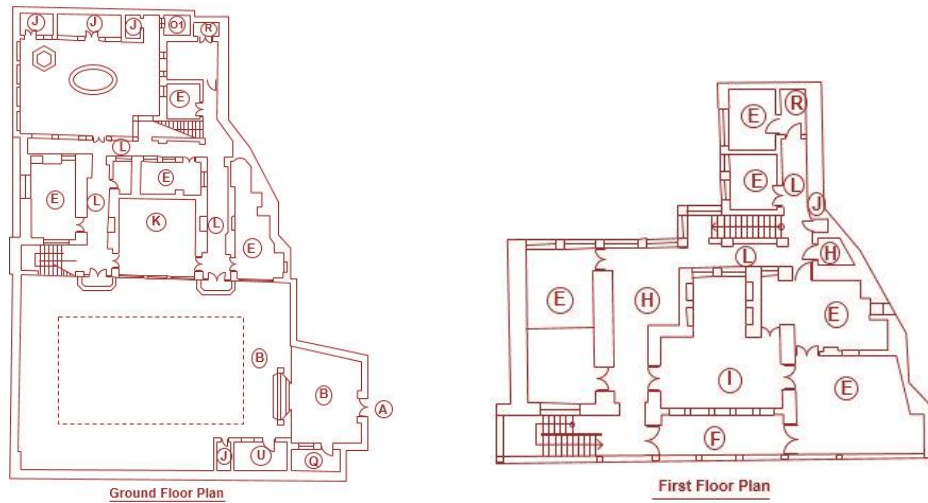

**Figure 11:** Architectural plan for the Ghadiri House (House 4) (Ministry of Housing and Urban Development of Iran, 1993)

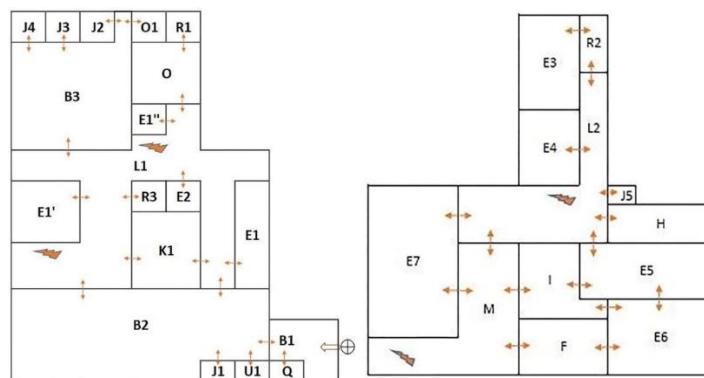

**Figure 12:** Convex Map for the Ghadiri house (House 4)

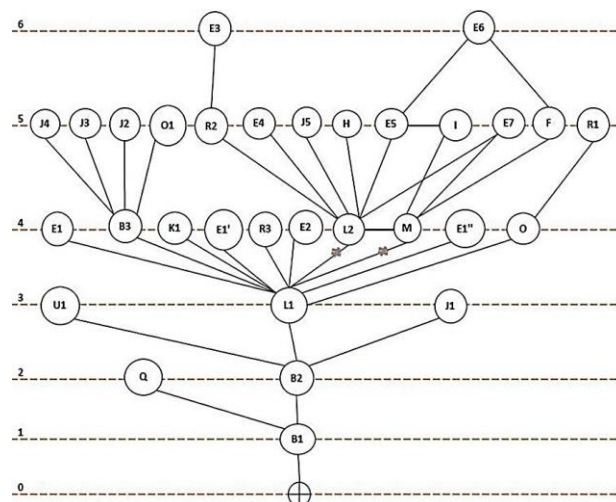

**Figure 13:** JPG, with exterior as carrier, for the Ghadiri house (House 4)

**Table 5:** Data summary for the Ghadiri House (House 4)

#	0	1	2	3	4	5	6	7	8	9	10	11	12	13	14	15	16	17
(V $\alpha$ )	$\oplus$	B1	Q	B2	U1	L1	J1	E1	B3	K1	E1'	R3	E2	L2	M	E1''	O	J4
TDn	131	101	131	75	105	55	105	85	77	85	85	85	85	67	72	85	83	107
MDn	4.23	3.26	4.23	2.42	3.39	1.77	3.39	2.74	2.48	2.74	2.74	2.74	2.74	2.16	2.32	2.74	2.68	3.45
RA	0.22	0.15	0.22	0.09	0.16	0.05	0.16	0.12	0.10	0.12	0.12	0.12	0.12	0.08	0.09	0.12	0.11	0.16
i	4.65	6.64	4.65	10.57	6.28	19.38	6.28	8.61	10.11	8.61	8.61	8.61	8.61	12.92	11.34	8.61	8.94	6.12
CV	0.33	2.25	0.33	2.42	0.25	7.28	0.25	0.09	4.09	0.09	0.09	0.09	0.09	4.62	1.72	0.09	1.09	0.20

#	18	19	20	21	22	23	24	25	26	27	28	29	30	31	Mean	Min	Max
(V $\alpha$ )	J3	J2	O1	R2	E4	J5	H	E5	I	E7	F	R1	E3	E6			
TDn	107	107	107	94	96	96	96	92	97	93	98	113	124	119	95.6	55	131
MDn	3.45	3.45	3.45	3.03	3.10	3.10	3.10	2.97	3.13	3.00	3.16	3.65	4.00	3.84	3.08	1.77	4.23
RA	0.16	0.16	0.16	0.14	0.14	0.14	0.14	0.13	0.14	0.13	0.14	0.18	0.20	0.19	0.14	0.05	0.22
i	6.12	6.12	6.12	7.38	7.15	7.15	7.15	7.62	7.05	7.50	6.94	5.67	5.00	5.28	7.87	4.65	19.38
CV	0.20	0.20	0.20	1.13	0.13	0.13	0.13	1.13	0.53	0.33	0.70	0.50	0.50	0.83	1.00	0.09	7.28
	H			0.958													
	H*			0.652													

### 3.4 KIA HOUSE (House 5)

Kia house is one of the monuments of Gorgan City during the Qajar period (1868) in tBagh Palang neighborhood, with an approximate area of 880 m<sup>2</sup> (Ministry of Housing and Urban Development of Iran, 1993). In Figure14, the architectural plan of this house is depicted. Figure15 shows the constructed convex map. Figure 16 illustrates the justified plan graph of house 5. Table 6 also shows a summary of the performed calculations related to this house.

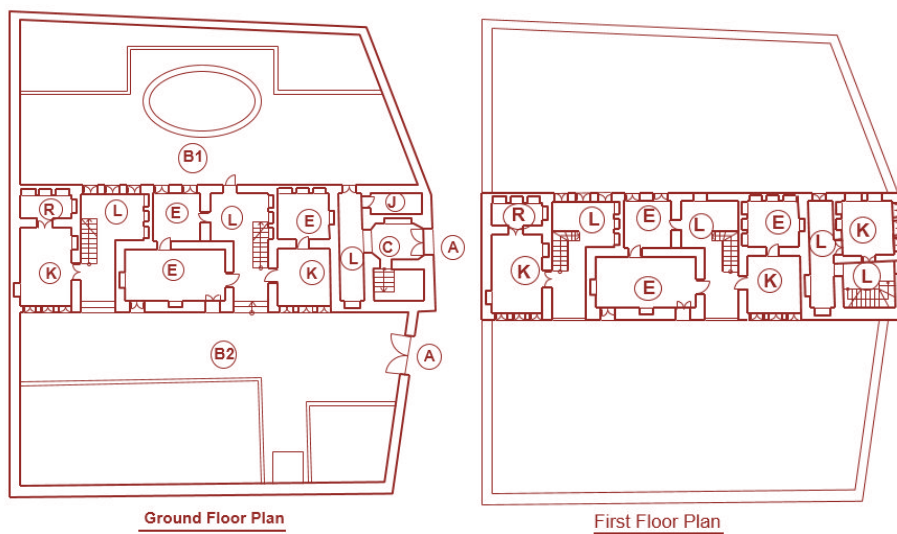

**Figure 14:** Architectural plan for the Kia House (House 5) (Ministry of Housing and Urban Development of Iran, 1993).

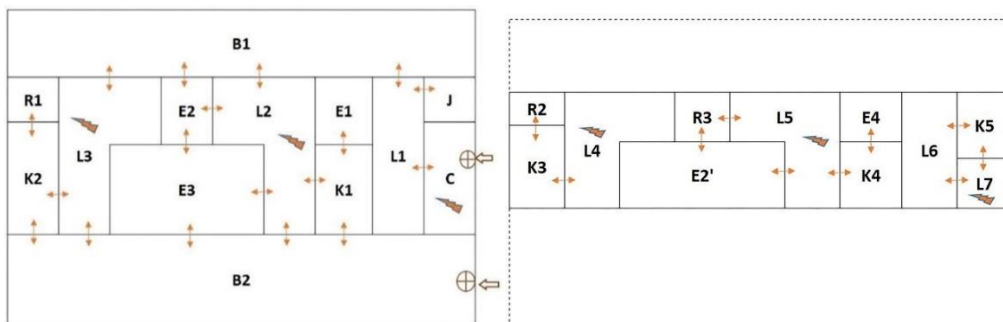

**Figure15:** Convex Map for the Kia House (House 5)

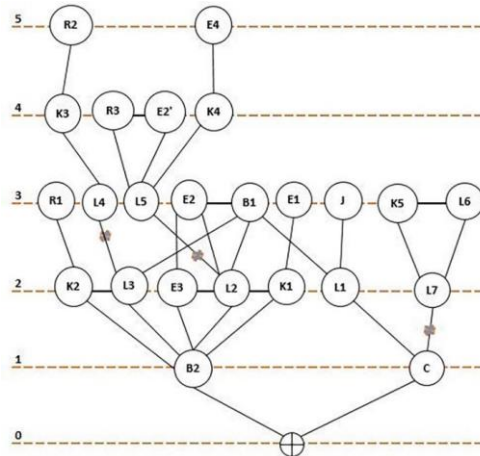

**Figure 16:** JPG, with the exterior as the carrier, for the Kia house (House 5).

**Table 6:** Data summary for the Kia House (House 5)

#	0	1	2	3	4	5	6	7	8	9	10	11	12	13	14
(V $\alpha$ )	$\oplus$	B2	C	K2	L3	E3	L2	K1	L1	L7	R1	L4	L5	E2	B1
TDn	69	58	80	72	67	71	60	69	73	98	95	86	76	78	60
MDn	2.88	2.42	3.33	3.00	2.79	2.96	2.50	2.88	3.04	4.08	3.96	3.58	3.17	3.25	2.50
RA	0.16	0.12	0.20	0.17	0.16	0.17	0.13	0.16	0.18	0.27	0.26	0.22	0.19	0.20	0.13
i	6.13	8.12	4.93	5.75	6.42	5.87	7.67	6.13	5.63	3.73	3.89	4.45	5.31	5.11	7.67
CV	0.50	1.92	1.17	1.42	1.25	0.67	1.67	1.33	1.58	1.33	0.33	0.75	1.67	0.75	1.08

#	15	16	17	18	19	20	21	22	23	24	Mean	Min	Max
(V $\alpha$ )	E1	J	K5	L6	K3	R3	E2'	K4	R2	E4			
TDn	93	94	121	121	107	97	97	96	130	119	87.48	58	130
MDn	3.88	3.92	5.04	5.04	4.46	4.04	4.04	4.00	5.42	4.96	3.65	2.42	5.42
RA	0.25	0.25	0.35	0.35	0.30	0.26	0.26	0.26	0.38	0.34	0.23	0.12	0.38
i	4.00	3.94	2.85	2.85	3.33	3.78	3.78	3.83	2.60	2.91	4.83	2.60	8.12
CV	0.33	0.33	0.83	0.83	1.50	0.75	0.75	1.25	0.50	0.50	1.00	0.33	1.92
H				1.000									
H*				0.757									

### 3.5 Fatemi House (House 6)

Fatemi house is one of the monuments of the Qajar period (1864) in Gorgan City, Sarkhajeh neighborhood, with an approximate area of 1200 m<sup>2</sup> (Ministry of Housing and Urban Development of Iran, 1993). In Figure 17, the architectural plan of this house is depicted. Figure 18 shows the constructed convex map. Figure 19 illustrates the justified plan graph of house 6. Table 7 also shows a summary of the performed calculations related to this house.

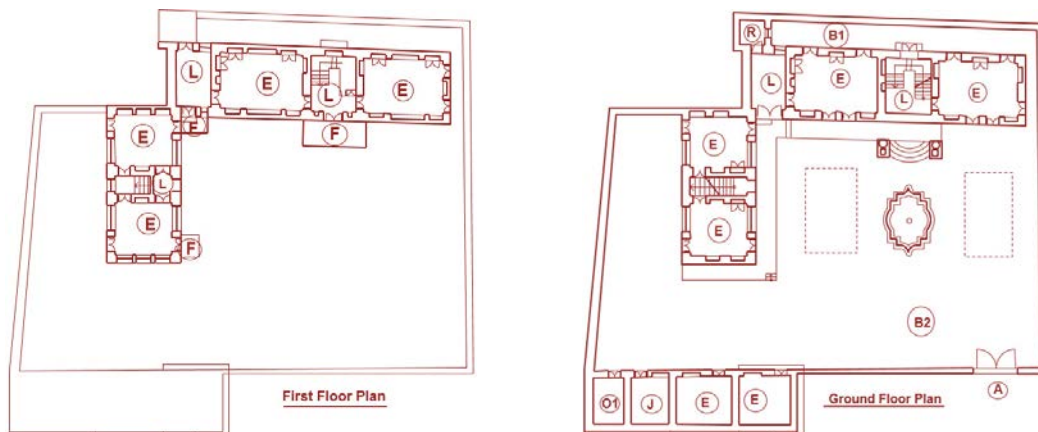

**Figure17:** Architectural plan for the Fatemi House (House 6) (Ministry of Housing and Urban Development of Iran, 1993).

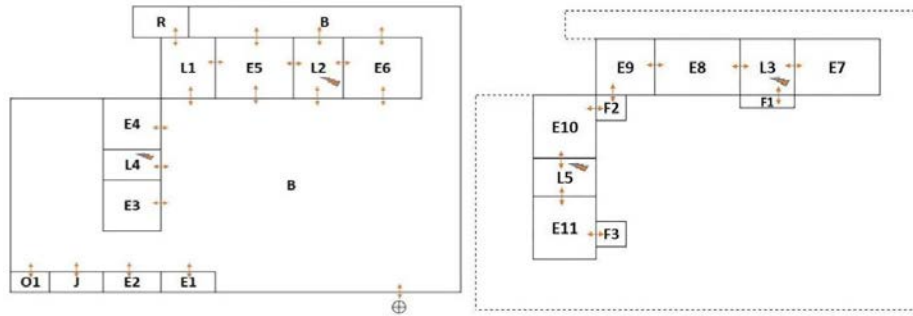

**Figure18:** Convex Map for the Fatemi House (House 6).

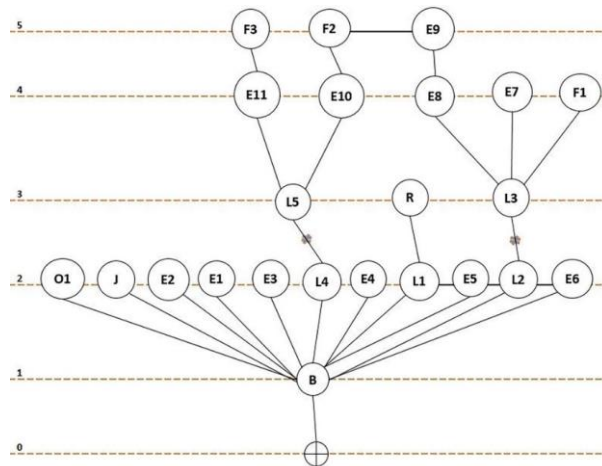

**Figure19:** JPG, with the exterior as the carrier, for the Fatemi House (House 6)

**Table 7:** Data summary for the Fatemi House (House 6)

$\neq$	0	1	2	3	4	5	6	7	8	9	10	11	12	13
(V $\alpha$ )	$\oplus$	B	O1	J	E2	E1	E3	L4	E4	L1	E5	L2	E6	L5
TDn	67	45	67	67	67	67	67	56	67	64	59	55	61	67
MDn	2.91	1.96	2.91	2.91	2.91	2.91	2.91	2.43	2.91	2.78	2.57	2.39	2.65	2.91
RA	0.17	0.09	0.17	0.17	0.17	0.17	0.17	0.13	0.17	0.16	0.14	0.13	0.15	0.17
i	5.75	11.50	5.75	5.75	5.75	5.75	5.75	7.67	5.75	6.17	7.03	7.91	6.66	5.75
CV	0.08	8.92	0.08	0.08	0.08	0.08	0.08	0.42	0.08	1.42	0.67	1.17	0.33	1.50

$\neq$	14	15	16	17	18	19	20	21	22	23	Mean	Min	Max
(V $\alpha$ )	R	L3	E11	E10	E8	E7	F1	F3	F2	E9			
TDn	86	66	86	81	78	87	87	109	92	89	72.38	45	109
MDn	3.74	2.87	3.74	3.52	3.39	3.78	3.78	4.74	4.00	3.87	3.15	1.96	4.74
RA	0.25	0.17	0.25	0.23	0.22	0.25	0.25	0.34	0.27	0.26	0.20	0.09	0.34
i	4.02	5.88	4.02	4.36	4.60	3.95	3.95	2.94	3.67	3.83	5.59	2.94	11.50
CV	0.33	2.75	1.33	0.83	0.75	0.25	0.25	0.50	1.00	1.00	1.00	0.08	8.92
H			0.975										
H*			0.695										

## 4. DISCUSSION

As shown in Table 8, the selected traditional houses have an area of 800 to 1200 m<sup>2</sup> and House 2 (Darooei) has the most node with 40 nodes and the house 3 (Kashani) has the least node with 16 nodes. Also, in terms of the number of levels, house 3 (Kashani) has the least level with the 3 levels and the house 4 (Ghadiri) has the most level with 6 levels. All plans are tree-like and symmetrical, and this attitude is being used for the well-being of the inhabitants.

**Table 8:** Data summary for all 6 Houses

Houses	Area (M <sup>2</sup> )	K	L	TDn	MDn	RA	i	H*
House 1 (Shafahi)	1000	27	5	96	3.7	0.22	5.06	0.797
House 2 (Darooei)	1000	40	4	132.5	3.5	0.13	8.10	0.747
House 3 (Kashani)	800	16	3	37.6	2.5	0.22	5.25	0.724
House 4 (Ghadiri)	800	32	6	95.6	3.1	0.14	7.87	0.652
House 5 (Kia)	880	25	5	87.5	3.6	0.23	4.83	0.757
House 6 (Fatemi)	1200	24	5	72.4	3.1	0.20	5.59	0.695

Comparing relative asymmetry (RA) in Table 8 shows that considering results are closer to zero than one, then all have symmetric structure, while linear and transverse structures have relative asymmetry close to one. Comparing the relative difference factor (H\*) also shows that all results are closer to one than zero. So all Houses are on the list of symmetric Houses. Figure20 shows that houses 2, 3, 5 and 6 in the courtyard space have the highest integration value. At the same time, houses 1 and 4 have the highest integration value related to the Veranda/Lobby of Ground floor. Figure 21 shows that in houses 1, 2, 3, 5, and 6, the courtyard space has the highest control value. However, at house 4, the highest control value is related to the Veranda/Lobby of Ground Floor. It should be noted that for ease of comparison, the number of nodes has been merged to the required extent.

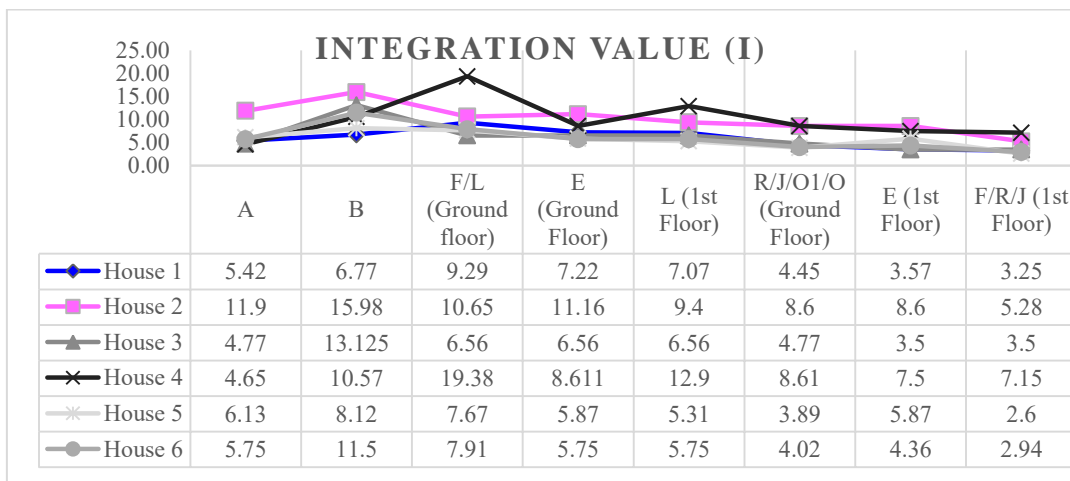

**Figure20:** Chart of integration value (For the all 6 houses)

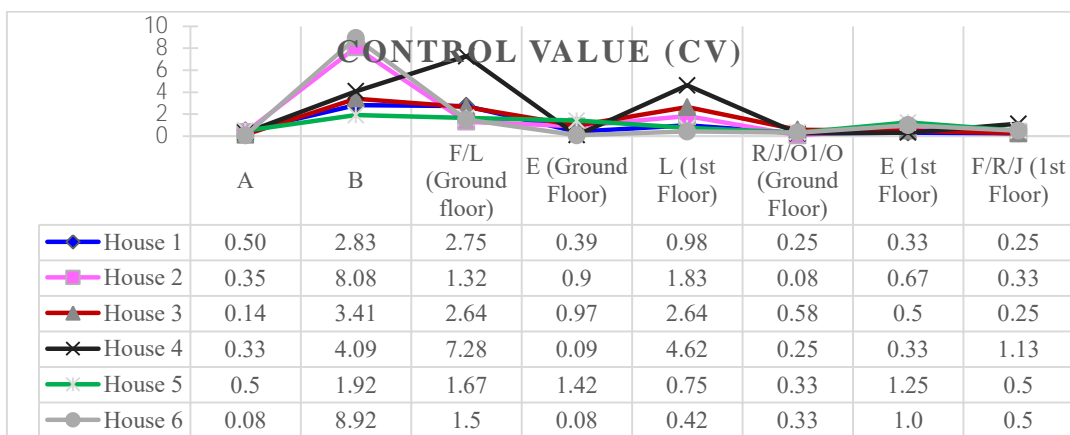
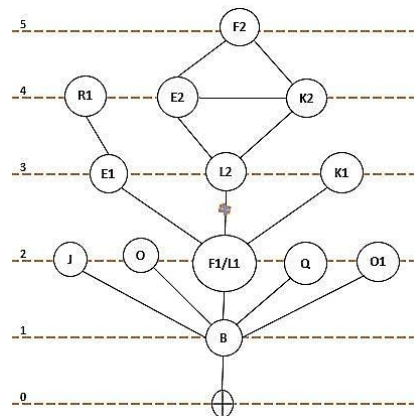

**Figure 21:** Chart of the control value (For the all 6 houses)

The configuration of all six houses is tree-like and symmetrical, which is 4 out of 6 cases, the courtyard has the highest integration value. In 5 out of 6 houses examined, the courtyard has the most



control value, which comes to the caretaker's room, kitchen, bathroom, and a veranda. In all the houses examined, there are two floors, which can be reached to the first floor by a hall or lobby through the staircase. In all cases, the first floor reaches a typical or three doors room, which ends on a balcony or a veranda. Considering all of these, an archetype pattern for the houses studied in the traditional houses of the moderate and humid regions of northern Iran can be considered as Figure 21, which is a tree-like and symmetric pattern. Assuming the above observations, the justified plan graph has 5 layers. In this pattern, three doors room (K1) is considered for the guest, which allows for a few days stay.



**Figure 22:** JPG Statistical Archetype, with the exterior as the carrier

As seen in the archetype diagram of the statistical model (Figure 22), the structure is symmetric and tree-like; the courtyard has the greatest spatial effect, and the first-floor closet has the highest depth and the least spatial effect. The inside of the yard includes a storage room, kitchen, bathroom, caretaker, and a veranda or hall, which reaches to typical and three doors rooms and a second-floor staircase. On the first floor, the lobby is connected to the typical and three doors room, which both end on the veranda. It should be noted that the general shape of the examined houses is an as high diagram, and for ease of comparison, the number of rooms is ignored, and houses with the same pattern can be placed in this category.

## 5. CONCLUSION

In this research, after preparing the architectural plan, the convex map and a justified plan graph, six traditional of moderate and humid climates in northern Iran were constructed. The constructed justified plan graph was specified the spatial and longitudinal depth communication of the spaces, followed by mathematical analysis and the calculation of the control values and the integration value for all spaces (nodes) and the mean and minimum the maximum of them was calculated and read. The mathematical results of each house, such as control value and integration value, showed beautifully that all the studied houses, regardless of form, are followed a single pattern in terms of the configuration and prioritization of the space.

Thus, according to mathematical calculations in most houses, courtyard and veranda with the highest integration value and control value respectively, have the most roles in the extrovert architecture of traditional houses in northern Iran. And the justified plan graph of the constructed archetype can be considered as a criterion for classifying houses in this climate. In order to preserve identity in the architecture of traditional Iranian houses, the justified plan graph and the control value



calculations and the integration value of the spaces can be used as a new method in the formatting and modeling of traditional buildings in other climates and different time periods can be used by architects, which is the way to achieve an identity and Iranian architecture from past monuments and, shape attitude is wrong.

## 6. DATA AVAILABILITY STATEMENT

Used or generated data is presented in this article.

## 7. REFERENCES

- Alizadeh, F., Lahiji, M. (2018). Suitable Delivery System in Small E-Commerce Companies. *Journal of Humanities Insights*, 02(04), 167-171.
- Lee, J. H., Ostwald, M. J., & Gu, N. (2018). A Justified Plan Graph (JPG) grammar approach to identifying spatial design patterns in an architectural style. *Environment and Planning B: Urban Analytics and City Science*, 45(1), 67-89.
- Ministry of Housing and Urban Development of Iran. (1993). New life- Old structure (A selection of valuable structures).
- Modaresi, N., Kazemi, M. (2019). Approach to Interaction-Oriented Spaces in Art and Architecture Faculty. *Journal of Humanities Insights*, 3(2), 57-60.
- Ostwald, M. J. (2011). A justified plan graph analysis of the early houses (1975-1982) of Glenn Murcutt. *Nexus Network Journal*, 13(3), 737-762.
- Ostwald, M. J. (2011). The mathematics of spatial configuration: Revisiting, revising and critiquing justified plan graph theory. *Nexus Network Journal*, 13(2), 445-470.
- Steadman, P. (1983). *Architectural morphology: an introduction to the geometry of building plans*. London: Pion.



**Atikeh Mohammadi Nasab** is a M.SC student in Architectural Engineering at Kowsar Institute of Higher Education, Iran. She graduated with B.SC in Architectural Engineering at Islamshahr Azad University with Distinction. Her fields of interest are scene and architectural design.



**Dr. Peiman Pilechiha** is an Assistant Professor of Architecture Department, Kowsar Institute of Higher Education, Iran. He earned a PhD in architecture from Tarbiat Modares University with Distinction. His fields of interest are Energy and Architecture.



**Mina Hajian** is a PhD student in Architecture at Bu-Ali Sina University, Iran. She got an MA in Architecture from Tarbiat Modares University, Iran. Her fields of interest are Computing and Mathematics Usage in Architecture.