



CFD Analysis on Heat Transfer Enhancement of Thermoelectric Generator Heat Exchanger for Low-Grade Heat Power Generation

Muhaammad Yusri Abu Haris¹, Baljit Singh^{1*},
Muhammad Fairuz Remeli¹, Amandeep Oberoi²

¹ Faculty of Mechanical Engineering, Universiti Teknologi MARA Malaysia, 40450 Shah Alam, Selangor, MALAYSIA.

² Mechanical Engineering Department, Thapar Institute of Engineering and Technology, Patiala, INDIA.

*Corresponding Author (Tel: +6013 5813432, Corresponding Author Email: baljit@uitm.edu.my)

Paper ID: 12A9L

Volume 12 Issue 9

Received 29 July 2021

Received in revised form 14 October 2021

Accepted 02 July 2021

Available online 06 July 2021

Keywords:

Computational Fluid Dynamics (CFD); Thermoelectric generator; Waste Heat; Fin Geometry; Flue-Gas; Heat Exchanger.

Abstract

This paper covers on computer simulation of waste heat recovery being released from the stack of waste heat boilers in a typical power station. A double pipe heat exchanger with a square inner pipe with thermoelectric generators was used. A series of fin geometry of the heat exchanger (normal fin, staggered square cross-section pin and staggered circular cross-section pin) was analyzed. Water liquid was used as a cold fluid and set as constant at 20°C with 0.02 kg/s throughout this analysis. On the hot fluid side, the temperature was varied from 40°C to 160°C with an increment of 40°C. From the analysis, by introducing turbulence flow, the heat transfer can be increased resulting in increased TEG performance. The maximum electrical powers produced were 29 W and 38 W for square cross-section pin and circular cross-section pin, respectively.

Disciplinary: Thermoelectricity; Thermal Engineering and Heat Transfer.

©2021 INT TRANS J ENG MANAG SCI TECH.

Cite This Article:

Haris, M. Y. A., Singh, B., Remeli, M. F., Oberoi, A. (2021). CFD Analysis on Heat Transfer Enhancement of Thermoelectric Generator Heat Exchanger for Low-Grade Heat Power Generation. *International Transaction Journal of Engineering, Management, & Applied Sciences & Technologies*, 12(9), 12A9L, 1-9. <http://TUENGR.COM/V12/12A9L.pdf> DOI: 10.14456/ITJEMAST.2021.180

1 Introduction

Low-grade heat has a low density of heat typically below 230°C and is not efficiently utilized by using conventional systems through the steam engine (i.e. Rankine cycle) (Remeli *et al.*, 2016). Combined cycle generation at the power station releases unused flue-gas at 160°C at the stack. Most of the industrial sector rejects waste unused heat amounting to about 33% (Shandilya *et al.*, 2017). As conventional energy (e.g. fossil fuel) is going to deplete, alternative way for efficient

energy consumption with cleaner technology is quite crucial nowadays (Kolambekar & Bhole, 2015). The most widely used method in utilizing waste heat is the direct utilization of the heat in the central heating of the four seasoned countries. This technology has the smallest investment cost and simple auxiliary system, thus the recovered heat can be used all year long and the investment has the shortest payback (Pintacsi & Buhari, 2013).

From the byproduct of the natural gas combustion, the flue-gas contains a large amount of water vapour with 10% to 11% (Zhao *et al.*, 2016). It is very important to know the existence of sulphur dioxide (SO_2) as it can form sulphuric acid when combined with water vapour as the temperature of the flue gas is below the dew point (Chen, 2012). As the temperature of the flue gas in power plants is 160°C , the water vapour inside the flue gas does not condense fully where latent heat cannot be reclaimed; hence, it will lead to heat loss. The saturated temperature of dry flue-gas was at 59.2°C (Zhou *et al.*, 2017). By increasing humidifying capacity, the moisture of the gas will increase, the temperature will decrease and the saturated temperature of the flue-gas will increase, thus latent heat can be retrieved easily.

For the high and medium grade waste heat, the conventional method through steam turbine Rankine cycle can be utilised (Teng *et al.*, 2007). TEGs can be used for low-grade heat. The usage of the thermoelectric generator as a device to convert heat into electricity has gained the attention of researchers in waste heat recovery. Simulation and experiments conducted on thermoelectric generators found that power output increased as the temperature difference between the hot and cold sides increased (Xiao *et al.*, 2008). This device does not contain any moving parts and can be easily maintained. The principle of thermoelectric generators works under the Seebeck effect where the power output is produced when a temperature difference exists between their two sides.

Thermoelectric material is based on semiconductor which has low thermal conductivity and high electrical conductivity. Bismuth telluride (Bi_2T_3) is the widely used material for the thermoelectric module as the maximum operating temperature is at 300°C ; thus, suitable for the low-grade waste heat retrieval. However, the generation efficiency of the thermoelectric generator is quite low, typically below 10%. A reliable heat exchanger design is crucial in determining the efficiency of the thermoelectric generator in retrieving waste heat in the industry.

The double pipe heat exchanger has drawn much attention due to its simplicity and wide range of usage. In recent years, several studies have been performed on the double pipe heat exchanger. By introducing a variety of geometry inside the pipe leads to an increase in turbulence; hence, increases the heat transfer rate, but at the same time increases the pressure drop. The optimum pressure drop is needed as the higher pressure drop needs a more powerful pump for the fluid to flow inside the heat exchanger, thus increases the overall cost. Selecting a particular design of fin geometry remains unclear. In this research, consideration is taken solely on the performance evaluation without considering the role of pressure drop and velocity which results in calculation hardly related to actual flow condition.

However, despite many studies on waste heat recovery on low-grade heat, there was no similar study found where hot working fluid applied the flue-gas from the exhaust of gas turbine power generation station and at the same time used thermoelectric generator as the device to retrieve the waste heat. The effect of the fin geometry towards the flue-gas and the heat transfer performance can be evaluated together with the thermoelectric generator efficiency.

2 Methodology

The basic dimension of thermoelectric modules was given as 40 mm × 40 mm × 4 mm. A double pipe heat exchanger was used in this project. The inner pipe was changed from the conventional circular pipe into a square pipe of 90 mm × 90 mm with a thickness of 5 mm. The length of the heat exchanger was approximately 320 mm so that each side of the square pipe can mount 18 TEGs modules, with a total of 72 TEGs modules used for a single heat exchanger. The material used for the square pipe was copper due to its high thermal conductivity. 5 mm thickness was used to ensure the heat was evenly distributed along the pipe, as the TEGs module near the outlet can receive heat with a similar temperature to the TEGs module near the inlet. The outer pipe diameter was 160 mm with a thickness of 3 mm made up of steel and insulated thoroughly. The counter flow fluid arrangement was chosen as the constant parameter for all cases in this project. Water liquid was chosen for the cold fluid which flowed in the outer shell of the heat exchanger, with the mass flow rate (0.02 kg/s) and the inlet temperature (20°C) also kept constant in all cases. For the hot fluid, flue-gas flowed inside the square pipe and the temperature was set at 40°C to 160°C with an increment of 40°C. For each set of temperature, the mass flow rate was set at 0.02 kg/s followed by 0.04 kg/s, 0.06 kg/s, 0.08 kg/s and 0.1 kg/s. As for the design inside the square pipe, there were a total of 4 designs (i.e., hollow, normal fin, staggered square cross-section pin and staggered circular cross-section pin) to be analysed in the Computational Fluid Dynamics (CFD) analysis.

2.1 Design Model

The model of the heat exchanger was designed in the CATIA V5R20 software. The dimension was solely new in this project with the fin geometry added inside the square pipe was the new design. The simulation drawing as in figure 1(b) was less complicated compared to the initial one (1(a)), as the inlet and outlet of the cold fluid were put as normal to the body. During the analysis stage, all four types of design were run in the simulation without mounting the TEGs module. In this case, the drawing was redundant since the upper and lower were the same; thus, it was decided to cut the drawing geometry into half to minimize the time of the calculation. The best two designs were chosen based on the result without TEGs. As TEGs was mounted on the heat exchanger, the number of elements increased drastically. In order to minimize it, only a quarter of the initial simplified drawing geometry was used to reduce the number of elements during the simulation of TEGs.

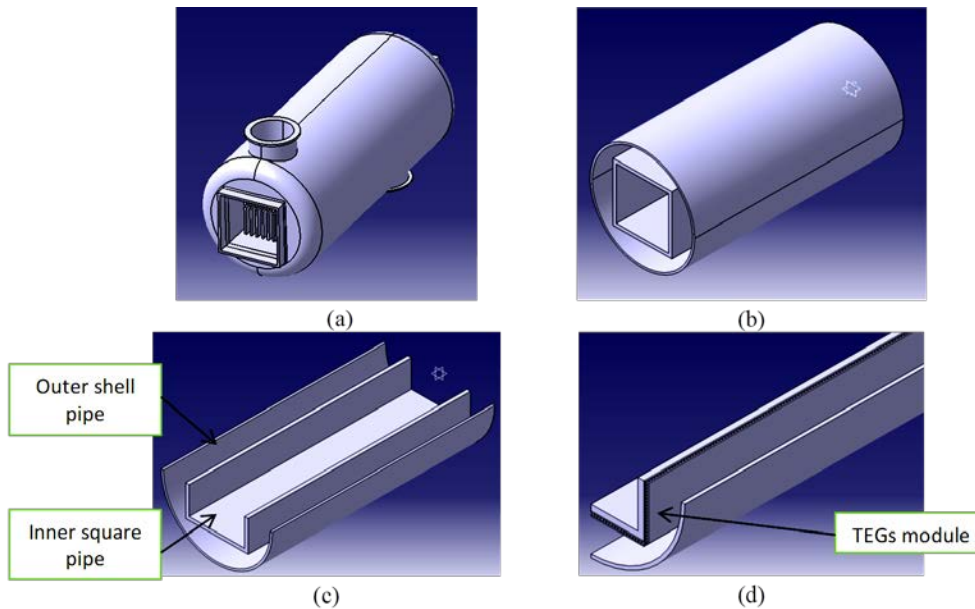

Figure 1: CAD drawing for the heat exchanger, (a) The initial detailed drawing geometry before simplified for the analysis; (b) The simplified drawing geometry for the analysis consists of the outer shell pipe and the inner square pipe only; (c) The simplified drawing geometry is cut into half as the geometry is symmetry; (d) TEGs attached to the pipe assembly

The meshing process was done under the ANSYS Meshing application. The mesh sizing was changed from Course into Medium. This process was based on the auto generate meshing for the whole geometry with the given type of model in terms of the tetrahedron, square cell or combination of both models depending on the complexity of the geometry.

3 Result and Discussion

The simulation was conducted on a TEGs heat exchanger with four different types of square pipe geometry. The mass flow rate and the inlet water liquid temperature were kept constant throughout the simulation at 0.02 kg/s and 20°C. The temperature difference at the inlet and outlet for both hot and cold fluid were measured and the total heat transfer was calculated.

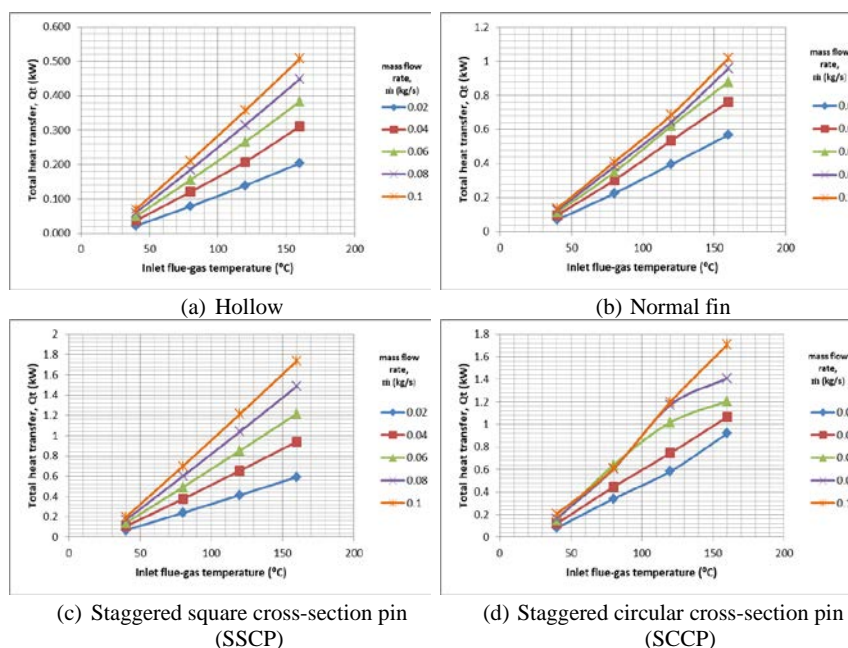

Figure 2: The graph shows the total heat transfer (\dot{Q}_t) versus inlet flue-gas temperature ($T_{h,in}$) for each heat exchanger design with different flue-gas mass flow rates.

The total heat transfer (Q_t) produced with respect to the inlet flue-gas temperature for its different mass flow rate can be seen in Figure 2. Based on the graph, all four types of heat exchangers with different geometry increased in Q_t when the inlet temperature ($T_{i.in}$) also increased. The same phenomena happened at the same $T_{i.in}$ since higher mass flow rate (\dot{m}) gave a higher Q_t value. For example, hollow type, 0.02 kg/s and 0.1 kg/s mass flow rate produced 0.2 kW and 0.5 kW Q_t respectively at $T_{i.in}$ 160°C. This is because the value of Q_t is directly proportional to (\dot{m}). The difference is less significant when the $T_{i.in}$ is low. All four types of heat exchangers gave the same pattern of graph for this case. By increasing (\dot{m}) or $T_{i.in}$, the value of Q_t produced also increased due to the increase of heat transfer.

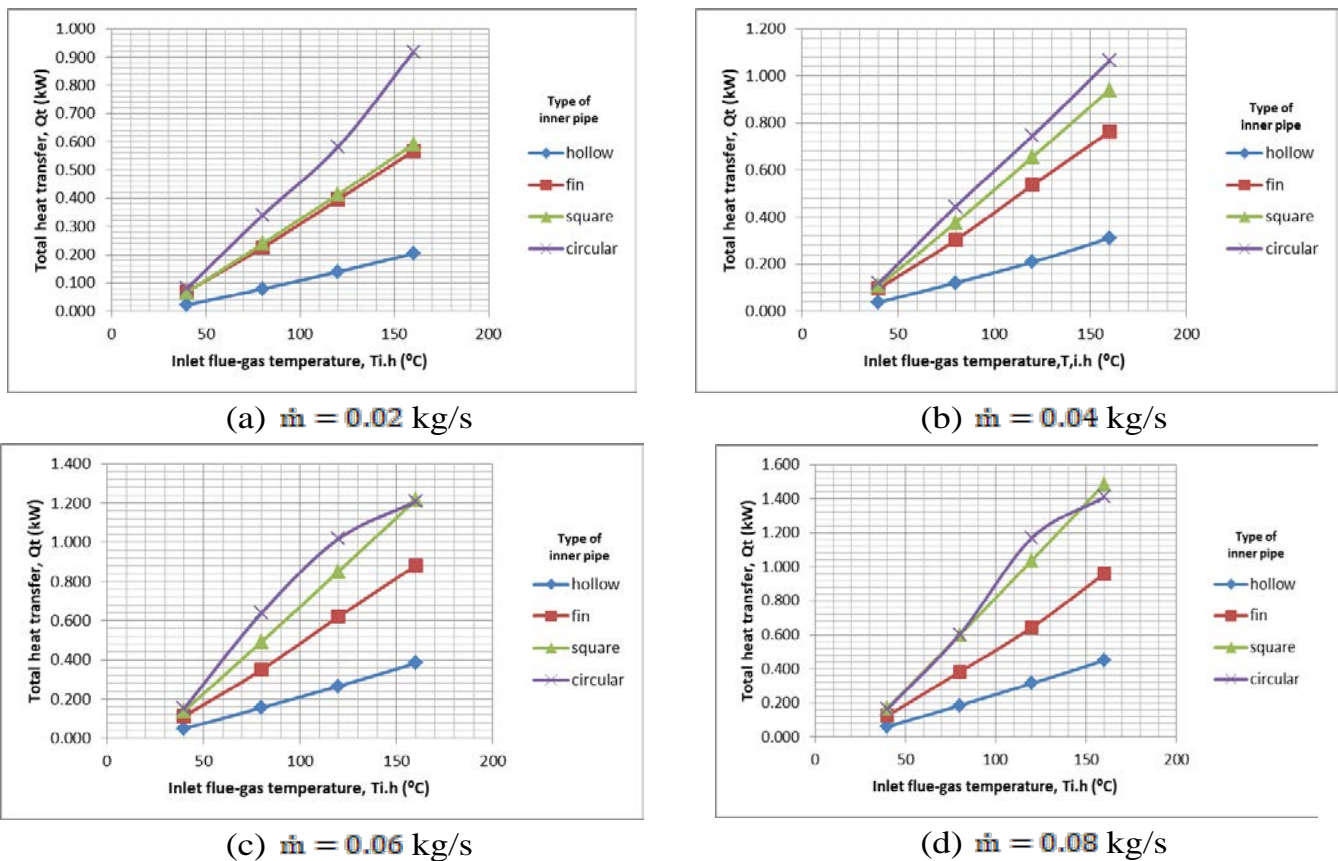

Figure 3: The total heat transfer (\dot{Q}_t) versus inlet flue-gas temperature ($T_{h.in}$) for each mass flow rate with different types of heat exchanger geometry design.

Figure 3 shows the comparison between each type of heat exchanger at the same mass flow rate (\dot{m}). For lower mass flow rate (e.g., 0.02 kg/s and 0.04 kg/s), the staggered circular cross-section pin (SCCP) heat exchanger produced the highest Q_t compared to the other heat exchanger. When reaching high (\dot{m}), the value Q_t produced was likely similar for **SSCP** and SCCP heat exchanger types.

From the graph, it can also be seen that without any fin geometry added in the square pipe, Q_t is low, due to less turbulent flow formed inside the square pipe. Introducing turbulent flow in the heat exchanger is crucial as the turbulent flow can increase the heat transfer. This is due to the violent mixing molecule of the fluid. For example, in laminar flow, the fluid molecule flow is linear

as the molecule has less heat in each other. As the heat energy cannot be transferred from one molecule to another, it slows the process of heat transfer in the fluid. In contrast, the violent flow of the fluid particle vigorously hits one another resulting in fast energy transfer and increases the heat transfer in the end.

Figure 4 shows the velocity vector profile for different types of heat exchangers. The comparison was done when the inlet flue-gas temperature was at 160°C with a mass flow rate of 0.1 kg/s. The velocity profile for the hollow type was almost uniform throughout the heat exchanger as there was no resistance in the flow. For the normal fin, the velocity profile was also uniform like a hollow design, but the value was much higher with about 50 m/s compared to the velocity in the hollow which was 39 m/s. The average velocity of SSCP and SCCP was 60 m/s and 40 m/s, respectively. The square cylinder had a larger turbulent wake compared to the circular cylinder. This flow does not contribute thermally, but it can cause large drag pressure, thus the heat exchanger needs a large amount of pumping pressure for the fluid to flow. The cost-effectiveness needs to be measured in this stage to find the optimum pressure drop useful for the heat exchanger, but at the same time does not require a large pump.

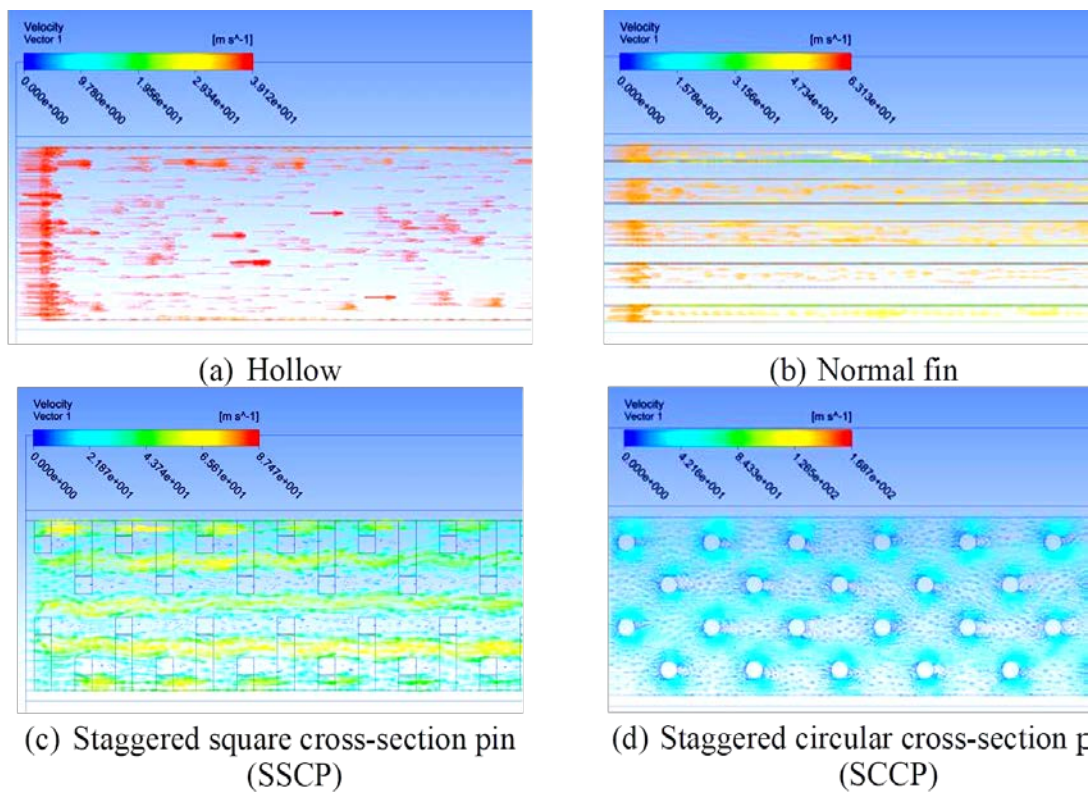

Figure 4: Velocity vector for the flue-gas flow over the different geometry designs inside the square pipe from the top view at mass flow rate 0.1 kg/s.

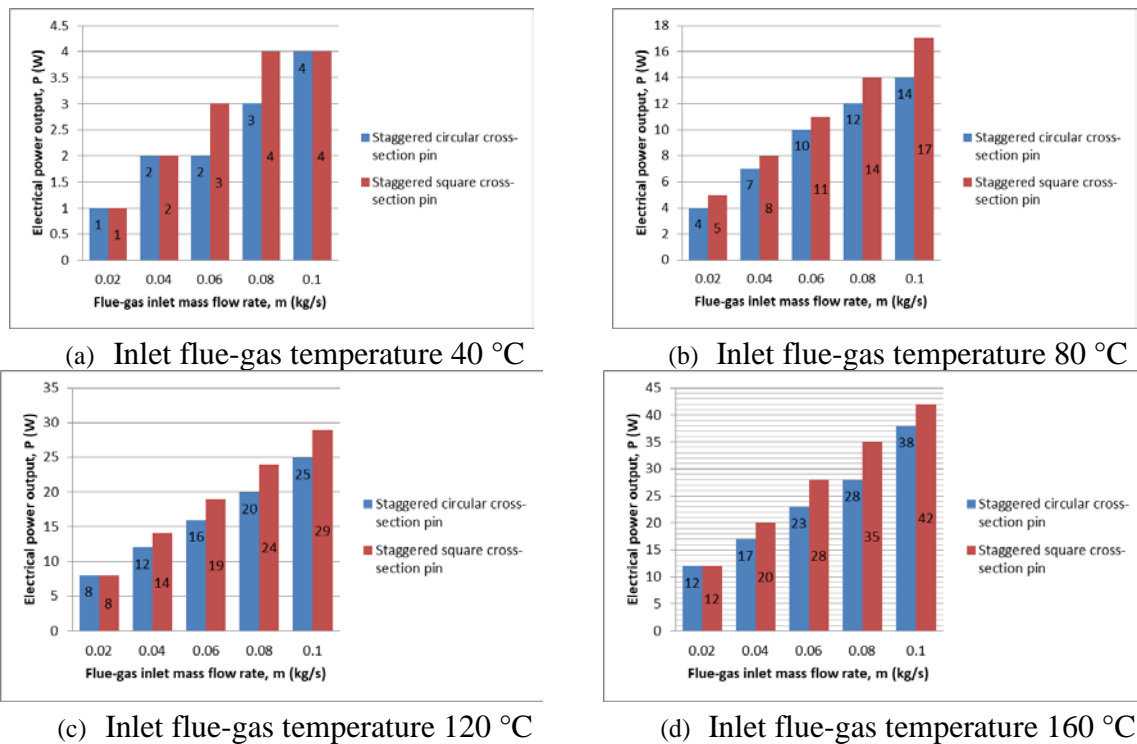

Figure 5: The electrical power output (P) versus the flue-gas inlet mass flow rate (\dot{m}) for both heat exchanger geometry at each inlet flue-gas temperature.

As discussed before, lower mass flow rate did not have a distinct difference in Q_t produced. When the mass flow rate reached 0.1 kg/s, the electrical power output produced for SSCP and SCCP was 42 W and 38 W, respectively, as shown in Figure 5. Since the T_{in} was lower, the value produced also decreased as it solely depended on the heat supply with a sufficient mass flow rate.

4 Conclusion

This project studied the performance of TEGs heat exchangers in generating electrical power output using waste heat through CFD analysis. The concept of double pipe is used due to its simplicity in design and operation. By introducing turbulence flow into the flue-gas, it can increase the heat transfer. The fin geometry using staggered square cross-section pin and staggered circular cross-section pin is the best design in this project in retrieving waste heat from the flue-gas compared to the other two designs which are hollow and normal fin geometry. By using 2% as the efficiency converting total power output into electrical power output, the highest electrical power output produced for the staggered square cross-section pin and staggered circular cross-section pin are 42 W and 38 W respectively.

5 Availability of Data and Material

Data can be made available by contacting the corresponding author.

6 Acknowledgements

The authors gratefully acknowledge the help of the Research Management Institute (RMI) UiTM for Project Number: 600-IRMI/DANA 5/3/REI (003/2018) research grant.

7 References

- Chen, Q., Finney, K., Li, H., Zhang, X., Zhou, J., Sharifi, V., & Swithenbank, J. (2012). Condensing boiler applications in the process industry. *Applied Energy*, 89(1), 30-36.
- Kolambekar, R. B., & Bhole, K. (2015). Development of prototype for waste heat energy recovery from thermoelectric system at Godrej Vikhroli plant. In *2015 International Conference on Nascent Technologies in the Engineering Field (ICNTE)* (pp. 1-6). IEEE.
- Remeli, M. F., Date, A., Orr, B., Ding, L. C., Singh, B., Affandi, N. D. N., & Akbarzadeh, A. (2016). Experimental investigation of combined heat recovery and power generation using a heat pipe assisted thermoelectric generator system. *Energy conversion and management*, 111, 147-157.
- Saidawat, Y., & Gupta, J. K. (2015). Power generation from waste heat extracted through clinker production in cement industry. *International Journal in IT & Engineering*, 3(6), 23-33.
- Teng, H., Regner, G., & Cowland, C. (2007). *Waste heat recovery of heavy-duty diesel engines by organic Rankine cycle Part II: working fluids for WHR-ORC (No. 2007-01-0543)*. SAE Technical Paper.
- Xiao, H., Gou, X., & Yang, C. (2008). Simulation analysis on thermoelectric generator system performance. In *2008 Asia Simulation Conference-7th International Conference on System Simulation and Scientific Computing* (pp. 1183-1187). IEEE.
- Zhao, X., Fu, L., Yuan, W., Li, F., & Li, Q. (2016). The potential and approach of flue gas waste heat utilization of natural gas for space heating. *Procedia Engineering*, 146, 494-503.
- Zhao, Y., Wang, S., Ge, M., Li, Y., & Liang, Z. (2017). Analysis of thermoelectric generation characteristics of flue gas waste heat from natural gas boiler. *Energy Conversion and Management*, 148, 820-829.



Muhaammad Yusri Abu Haris is a student at Faculty of Mechanical Engineering, Universiti Teknologi MARA Malaysia. He obtains a Bachelor's degree in Mechanical Engineering from Faculty of Mechanical Engineering, Universiti Teknologi MARA, Malaysia. His research focuses on CFD of Heat Exchanger.



Dr. Baljit Singh is a Senior Lecturer at Faculty of Mechanical Engineering, Universiti Teknologi MARA, Malaysia. He obtained his Master's degree from Universiti Sains Malaysia and a Ph.D degree in Mechanical Engineering from RMIT University, Australia. His research focuses on Thermoelectricity, Thermal Engineering and CFD.

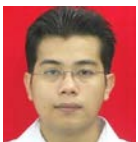

Dr. Muhammad Fairuz Remeli is a Senior Lecturer at Faculty of Mechanical Engineering, Universiti Teknologi MARA, Malaysia. He obtained his Ph.D degree in Mechanical Engineering from RMIT University, Australia. His research focuses on Thermoelectricity, Thermal Engineering and Heat Transfer.



Dr. Amandeep Oberoi is an Assistant Professor in the Mechanical Engineering Department at Thapar Institute of Engineering & Technology Patiala, India. He received his Ph.D from the RMIT University, Australia. His research focus includes Solid-state Hydrogen Storage, Proton Electrolyte Membrane Fuel Cells (PEMFCs), Heat Pipes and Heat Sinks.