**PAPER ID: 11A03Q**

## SEGMENTAL LINING GROUT SOLUTIONS FOR THE CONSTRUCTION OF TUNNELS AND MINING GALLERIES

Anischenko V.I.<sup>a,b</sup>, Atrushkevich V.A.<sup>b</sup>, Golik V.I.<sup>c\*</sup>, Alberto N. Rodriguez<sup>b</sup>

<sup>a</sup> Spetsmodulproject LLC, RUSSIA.

<sup>b</sup> Mining Institute, National University of Science and Technologies (NUST MISiS), Leninsky Prospect, 6, Moscow, RUSSIA.

<sup>c</sup> North Caucasus Mining and Metallurgical Institute (State Technological University), Geophysical Institute of the Vladikavkaz Scientific Center, the Russian Academy of Sciences, 362021, Vladikavkaz, Cosmonaut Nikolaev Street, 44, RUSSIA.

### ARTICLE INFO

#### Article history:

Received 06 May 2019  
Received in revised form 19  
September 2019  
Accepted 30 September 2019  
Available online 29 November  
2019

#### Keywords:

Grout rheology;  
Construction workings;  
High-precision lining;  
Tunneling complex;  
Cement slurry;  
Reinforcement  
solutions.

### ABSTRACT

The article deals with the selection of the composition of cement slurries for the construction of mine workings with concrete lining and high-precision segment lining. When using cement slurries to fill the space between the lining and the rock containing the mining output, the solution prepared from locally available materials may not meet the requirements, and the use of imported ready-mixed mixtures will be unacceptably expensive. Optimization of application modes of cement slurries in the construction of tunnels with a segment lining to increase the reliability of powerful and high-performance equipment. Systematization of the theory and practice of building tunnels with high-precision lining using mechanized tunneling complexes. Mathematical descriptions of the processes, experimental modeling of the obtained dependencies, and emergencies associated with the preparation of cement slurries are systematized. A description of the rheology of the cement slurry in the process of lining and the mechanism of the solution-rock mass system is given. The results of the experiment on the reinforcement of cement and lime cement slurries are given. The expediency of the solution reinforcement was confirmed not only for the formation of thixotropic properties but also for the maintenance of suspension. The results of a critical assessment of the components of cement slurries in relation to their use in mechanized tunnel complexes are given. The parameters for the preparation and use of mixtures should be selected on the basis of the results of comprehensive studies in specific conditions. The quality of preparation of the cement mixture in a complex increases the efficiency of the use of mechanized tunnel complexes.

**Disciplinary:** Tunnel Engineering, Concrete/Cement Technology.

© 2019 INT TRANS J ENG MANAG SCI TECH.

## 1. INTRODUCTION

During preparation for tunnel construction, a set of factors are taken into account, including the choice of penetration technology, the possibility of penetration and mine construction and its infrastructure provision with materials and transport, the safety conditions of the enclosing massifs and the earth surface, etc. An underestimation of the importance of these factors leads to abnormal emergencies (Atrushkevich & Atrushkevich, 2014; Adibi et al, 2015).

One of the most important issues is the type and the properties of grouts for filling the space between the lining and the ground. The grout prepared from scrap materials may not meet the requirements or be very expensive due to the use of imported ready-made mixtures and insufficient use of local ingredients (Galaov et al, 2014).

The rate of penetration largely depends on the quality and composition of grouts; therefore, the goal of the study in this area and this work is to optimize the use of grouts in the construction of tunnels with a segment lining (Kissin et al, 2017; Budach, 2010).

## 2. STUDY METHOD

To create a database, information is systematized on the construction of tunnels with high-precision lining and a detailed theory and practice of segmental lining using mechanized tunneling complexes with grouts. The analysis is accompanied by the mathematical description of technological processes. In order to check the correctness of the obtained models, experimental reinforcement of cement and lime grouts is carried out. Based on the obtained dependencies, recommendations are given on the practical implementation of the proposed technology.

## 3. RESULTS

Grouts for the construction of tunnels with high-precision lining perform the following functions:

- distribution of ground and hydrostatic stresses;
- preservation of the form and development stability;
- waterproofing and prevention of concrete natural leaching.

When they develop tunnel construction projects, the depth conditions, tectonics, petrographic and mineralogical composition, fractures and the nature of rock fracture substitution are taken into account.

During the construction of tunnels with segmental lining and the use of mechanized tunneling complexes, not only the properties of the cement stone are taken into account, but also its mobility during the required time.

This is due to the fact that the solution enters the system of the tunnel complex using the system of pumps with certain characteristics, including rheological parameters. The most common problems associated with the use of grouts are summarized in Table 1.

The tunnel cementation program includes the following steps:

- 1) selection of mixture components and their preparation parameters;
- 2) experimental verification under actual penetration conditions and recipe adjustment;
- 3) grout quality control during use.

**Table 1.** Emergency situations associated with grout preparation

Cause	Problem	Solution
Fractions of more than 0.7 mm in grout composition: pebbles or small stones	The failure of pump cuffs and sleeves. Abrasive wear. Failure of rubber couplings. The failure of pump rubber parts. Channel-lock.	Replacement of pump parts, flushing of pumps and channels. Sift the solution through a sieve, use fine sand.
High water loss coefficient (over $200 \times 10^{-3} (\text{min})^{-1/2}$ )	Pumps squeeze out water from the grout under pressure. The dry mixture remains in the channels. The discharge pressure is higher than the groundwater pressure; the free water falls inside the shield under pressure. The conditions for the formation of high-quality cement stone deteriorate.	Flush pumps and channels from the dry fraction. Use special additives to reduce water loss. The more granulometric composition of the components, the easier to "squeeze" water from the grout.
Fast setting time of the grout (less than 6 hours)	The grout hardening at various stages of its delivery into the annular space leads to the blocking of channels and the failure of pumps. Downtime is inevitable, and the service life of the pumps is reduced.	Provide for the availability of spare channels for pumping the grout in the complex. Use mineral or organic setting retarders.
The rheological properties of grout do not provide their mobility.	There is not enough pump power, they are switched off by current, increased wear of equipment, increased energy consumption. Increased discharge pressure, too much pressure on the ring, ring "folding", a traumatic situation.	Use plasticizers, control the discharge pressure according to the ring strength condition.
Long sitting time (over 14 hours)	Uneven distribution of grout in the tunnel, the displacement of the tunnel axis upwards (with the rod ascent) or downwards.	Retarder amount control. Caution when you work with salts. The use of organic retarders.

The grout rheology is characterized by structural (apparent) viscosity, cohesive strength, and internal friction. The behavior of the Newtonian fluid and the suspension of Bingham is characterized by Figure 1.

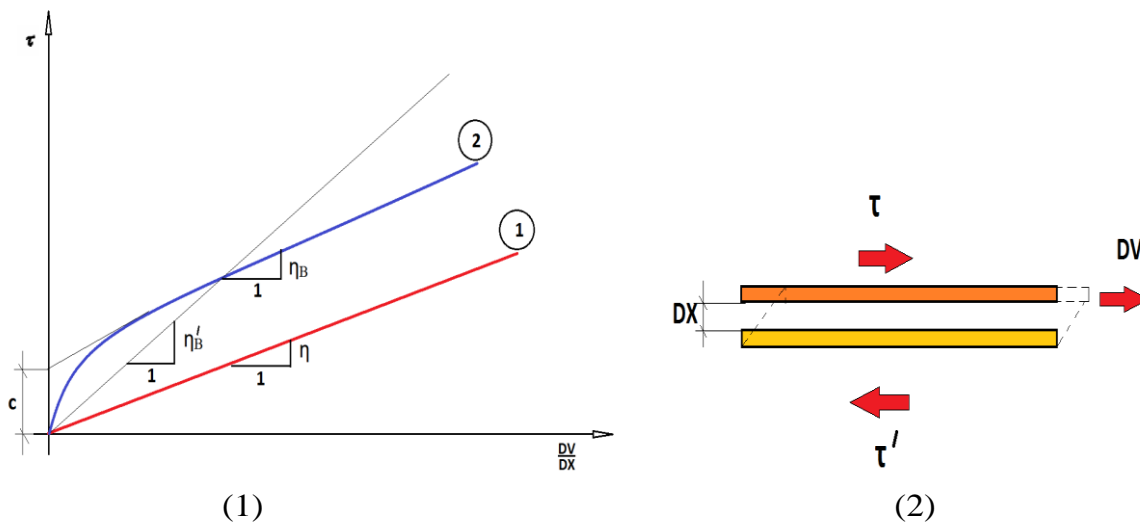

**Figure 1:** The rheology of Newtonian fluid (1) and Bingham solution (2).

Figure 1, the upper diagram determines the viscosity property difference between the liquid and the grout. The bottom diagram defines the shear properties of the solution. The viscosity of the mixture is directly proportional to the shear resistance and inversely proportional to the grout shear rate:

$$g = (V_2 - V_1) / dx \text{ (sec}^{-1}\text{)} \tag{1}$$

Where

g – the shear rate,  $\text{sec}^{-1}$ ;

$V_2$  – the lower layer speed, m/s;  
 $V_1$  – the upper layer speed, m/s;  
 $dx$  – the distance between the layers, m.

The equation for the curve 1:

$$\tau = \eta \times DV / DX \quad (2).$$

The equation for the curve 2:

$$\tau = C + \eta_b \times DV / DX \approx \eta' \times DV / DX \quad (3),$$

where  $\eta$  is the dynamic viscosity;

$\eta_b$  is plastic viscosity;

$\eta'$  is structural viscosity;

$C$  - cohesive strength.

These math models of state are derived without taking into account internal friction. Cohesive strength corresponds to shear strength. In the case of a Newtonian fluid, the cohesive strength makes zero, and the plastic and structural viscosity have the same magnitude, which is the dynamic viscosity.

Figure 2 illustrates the behavior of the grout with regard to internal friction and shear resistance, which varies with the fluid pressure.

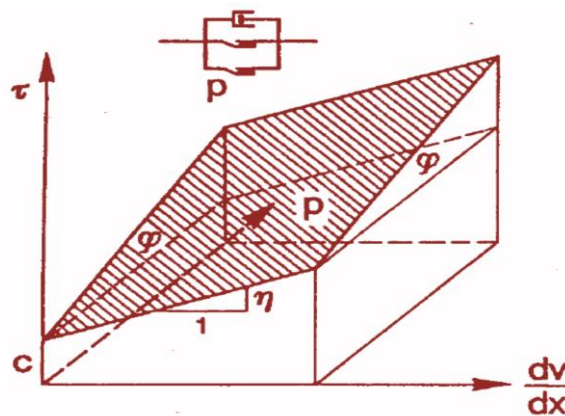

**Figure 2:** Suspension properties with regard to internal friction.

$$\tau = C + \eta_b \times DV / DX + p \times \tan \phi \quad (4),$$

where  $p$  - pressure;

$\tan \phi$  - the tangent angle of grout internal friction.

The unstable grout behaves as a Newtonian fluid, or as Bingham suspension with internal friction. The grout with significant internal friction is difficult to deliver to the annulus. Cohesive strength indicates how deeply the grout penetrates the hole of a certain radius under a certain pressure, while viscosity determines the flow rate of a stream under a certain pressure.

Low viscosity ensures the grout, coarse sand or weakly fractured rock penetration into the soil with small pores.

The high cohesive strength of the grout is not a disadvantage since there is no task to penetrate into the soil (Jarvie-Eggart, 2015).

During the selection of grout thixotropic properties, one should strive to ensure that the grout

becomes less viscous and lose some of its strength during pumping, and when it is stopped in the annular space, it gains maximum strength. This can be achieved by using polymer reinforcement of the grout with the chains of long polymer molecules.

We carried out the experiment on the reinforcement of cement and lime grouts in the laboratory. The grout components and the polymers were mixed in the water separately. Thus the thixotropic properties of the grout improved dramatically. The water loss coefficient decreased by more than 10 times, and there was practically no water distribution. It has been established that it is impractical to apply salt retarders in polymer reinforcement of the grout. Instead of mineral retarders, it is recommended to use organic polymer retarders, which creates significant savings.

Experimentally obtained side effect of polymer component interaction: in the absence of turbulence (without stirring), the filtration of water into the solution slowed down. This has a positive effect on the quality of cement stone when sinking in severely watered conditions.

The grout reinforcement is necessary not only for the formation of thixotropic properties but also to maintain suspension. It is important to prevent the formation of sludge in the pipes and pumps of the tunnel complex at the time of stopping during ring mounting. If the installation of one ring will take 3-4 hours, and the freezing time of the solution is 6 hours, with round-the-clock penetration, you will not have to waste time washing the pumps and channels. They will be cleaned in the following portions of the solution. Figure 3 shows the maintaining cement by using polymer reinforcement of the grout with the chains of long polymer molecules in practical. Figure 4 shows a tunnel needing maintenance.



**Figure 3:** Grouting application using the chains of long polymer molecules reinforcement.



**Figure 4:** Tunnel maintenance

The first step after tunnel drilling is to control the tunnel stability to ensure the safety required during drilling and their long-term stability. In general, the Earth is under natural, gravity and tectonic forces. As a result of tunnel excavation, the balance between these forces is disrupted and a new stress situation is created which may cause the ground around the tunnel to break down.

The main part of the solution is not cement, but a mineral binding filler, for example, fly ash or slag flour. The amount of sand is reduced, which positively affects the rheological properties without reducing the cement stone strength.

The solution with increased mobility must include a sufficient number of small particles in order to maintain the properties of the gel, stability under pressure and gain strength over a certain period of time. The use of a water-cement ratio of more than 1.5 leads to loss of stability and increased water loss and water separation. Using a 0.45 ratio increases equipment wear.

For the manufacture of highly mobile grouts they use Portland cement, which is classified by the following types (Golik et al, 2018; Golik et al, 2016):



- 1) in the absence of specific requirements and special technical restrictions;
- 2) for resistance to sulfate components of soil and water and upon presentation of special requirements for the cement crystallization temperature;
- 3) to increase the strength properties in two-component solution quickly for the creation of mixtures penetrating into microcracks;
- 4) It produces less heat than type 2 when it hardens and gains strength slower than type 1, and it is used to move large masses of cement and high temperatures if necessary;
- 5) with increased sulfate exposure.

Plasticizers, for example, naphthalene sulfonate, lignosulfonate and melamine-based materials transfer a negative charge to each cement particle, the particles repel each other. The use of these substances reduces the viscosity of the solution since the distance between the cement particles is increased and the structure-forming components penetrate between them. The strength of the resulting sample may be higher. The traditional proportion is from 0.5% to 2% of cement weight. Lingsulphates slow down the crystallization process.

Bentonite powder stabilizes the mobile solution, increases its mobility and reduces filtration resistance, increasing the viscosity, but reduces the strength of the cement stone. Magnesium bentonite type of Wyoming powder is recommended. Adding bentonite to the cement mixture increases its viscosity and can create problems with the mixer. However, upon further stirring, the viscosity of the solution decreases, because negatively charged particles of bentonite are attracted to positively charged particles of cement. Bentonite is shut in water for 12 hours prior to mixing, or a pump-mixing unit is used. No more than 5% of bentonite of cement weight is added due to the stone strength reduction.

Fly ash - pozzolanic mineral components that improve the distribution of particles in the solution, reduce water loss and increase the stability of the solution. Ashes go well with lime mortars and cement substitutes. When they use type C ash with more than 20% of cement weight, there are problems with mortar stability.

Sand dust, for example, ground sand with the size of less than 1 micron improves the structural properties of the solution and the distribution of particles in it when less than 10% of cement weight is used.

Organic resins are the additives that improve the thixotropic properties of the solution and reduce filtration and hydration. Proportions are highly dependent on the presence of other components and their chemical composition, the pH of water and mortar, soil, and usually make up 0.1 - 0.2% of cement weight.

Organic washout additives, for example, poly cellulose molecules reduce water separation and filtration, improving rheological properties. Some of them are not compatible with naphthalene sulfonate polymers and are limited for use with exopolysaccharides. The proportion makes from 0.2 to 1% of cement weight.

Stabilizers and accelerators are used most often in two-component solutions. The stabilizer coats the cement particles and prevents it from hardening for 72 hours. After that, accelerators are added to the solution and the accelerated crystallization process begins. Calcium chloride or sodium silicate is added to water and its amount makes no more than 20% of cement weight, given that the reaction occurs with the release of a large amount of heat.

## 4. CONCLUSION

The design of the cementing process is an important step for tunnel construction preparation, where errors are accompanied by a significant increase in work cost and penetration rate slowdown. The parameters for the preparation and the use of mixtures are selected according to the results of laboratory and field tests. A simple tunnel complex with a diameter of 4 meters costs more than 30 thousand euros per day, and larger diameter is several times larger, so the error causes large losses.

## 5. AVAILABILITY OF DATA AND MATERIAL

Data can be made available by contacting the corresponding authors

## 6. REFERENCES

- Adibi, N., Ataee-pour, M., & Rahmanpour, M. (2015). Integration of sustainable development concepts in open pit mine design. *Journal of Cleaner Production*, 108, 1037-1049.
- Atrushkevich V. A., & Atrushkevich, A. V. (2014). Development of integrated technical systems of mining enterprises. *Gornyj informacionno-analiticheskij byulleten'*, 1, 368-365. [In Russ]
- Budach, C. (2010). Neue Untersuchungen zur Konditionierung von Lockergesteinen bei Erddruckschilden. *FELSBAUMAGAZIN*, (5).
- Galaov, R. B., Nagovitsin, Yu. N., Pliev, B. Z., Andreev, A. A., & Vilchinsky, V. B. (2014). Improving the methods of fixing workings in the mines of the ZF of OJSC MMC Norilsk Nickel. *Gornyi Zhurnal*, 4, 25-28. [In Russ]
- Golik, V. I., Dmitrak, Yu. V., Maksimov, R. N., & Lyashenko, Yu. M. (2018). Use of ore dressing tailings in hardening mixtures. *Gornyj informacionno-analiticheskij byulleten'. Special'nyj vypusk*, 6, 56-64. [In Russ]
- Golik, V. I., Lyashenko, V. I., & Lukyanov, V. G. (2016). Artificial ceramics in underground mining of ores. *Ustojchivoe razvitie gornyh territorij*, 3, 248-255. [In Russ]
- Jarvie-Eggart, M. E. (2015). Responsible Mining: Risk Management in the Developed World. *Englewood. - Colorado. - Society for Mining, Metallurgy and Exploration*, 804 p.
- Kissin, A., Tomilina, A., & Komashchenko, V. (2017). Roads of the Southern Ural mountains. *Earth Science Frontiers*, 1-8.



**Vasily V. Anischenko** is an undergraduate student of NUST MISIS, studying upon program of Technological Machines and Systems. He is the General Director of LLC Spetsmodulproekt. He is a specialist in the field of Development of Mineral Deposits, Underground Construction and Drilling of Wells of Complex Profile.



**Professor Dr. Viktor A. Atrushkevich** is Professor at the Department of Geotechnology for the Subsoil Development, National University of Science and Technologies (MISIS), Russia, Director of the Center for Advanced Engineering of Mining Engineers of the Moscow Mining Institute NITU MISIS. He holds a Doctor of Technical Sciences degree. His areas of scientific interests include Integrated Mineral Mining and Processing Technologies, the Creation of Innovative Environmental- and Human-Friendly Mineral Mining and Processing Technologies in the process cycle of Mining Enterprises, the Combined Development of Stratum Deposits, Resource-Saving Technologies in Mining and Power Industry.



**Professor Dr. Vladimir I. Golik** is Professor at the Geophysical Institute - the Affiliate of Vladikavkaz Scientific Centre of the Russian Academy of Sciences, Professor of the Mining Department of the North Caucasus State Technological University, Russia. His specialisations are in the field of Development of Mineral Deposits, Methods of Extraction of Metals by Leaching, Utilization of Waste Mining and Processing of Minerals with the Activation of Components.



**Alberto Martin Nunez Rodriguez** is a postgraduate student at NUST MISIS. He is an Engineer of Mining.