

PAPER ID: 11A13K



BEHAVIORAL PERSPECTIVES AMONG DIVIDEND POLICY AND ITS DETERMINANTS AND FIRM'S FINANCIAL PERFORMANCE: A CB-SEM APPROACH

Sarfraz Ahmed Bhutto^{1*}, Hassan Jawad Soomro¹, Saifullah Shaikh¹,
Hussain Amar², Qamar Abbas Mangi¹

¹ Institute of Commerce, Shah Abdul Latif University Khairpur, Sindh, PAKISTAN.

² Government Islamia Arts & Commerce College, Sukkur, Sindh, PAKISTAN.

ARTICLE INFO

Article history:

Received 01 April 2020

Received in revised form 15 June 2020

Accepted 04 July 2020

Available online 15 July 2020

Keywords:

Effective dividend policy, Company's financial performance, SEM analysis; Stakeholders' interests; Structural Equation Modeling (SEM); Chief financial officer (CFO); Corporate finance; Anticipated level of future earnings; Patterns of past of dividends; Investment uncertainty; Manufacturing firms.

ABSTRACT

Dividend policy is the prime concern for every shareholder. Financial managers formulate the necessary dividend policy that increases shareholders' affinity towards the company. This study examines the relationship between determinants of dividend policy (anticipated level of future earnings, stakeholders' interest, the pattern of past dividends, corporate social responsibility (CSR), and uncertainty) and financial performance. Moreover, this study empirically investigates the untapped mediating effect of dividend policy between determinants of dividend policy and financial performance. Financial managers are highly integrated into formulating dividend policy, the present study indulged with the behavioral responses taken from Chief financial officers (CFOs) of listed manufacturing firms of Pakistan. Questionnaires are used as a study tool. The population frame includes CFOs of different financial and non-financial sectors. From the Covariance-based Structural Equation Modelling (CB-SEM) analysis, results show a significant relationship between the determinants of dividend policy and financial performance. Further, dividend policy mediates the relationship between its determinants (except uncertainty and CSR) and the firm's financial performance. The practical implication would be recommended for financial managers and other corporate policymakers.

Disciplinary: Management and Financial Sciences.

©2020 INT TRANS J ENG MANAG SCI TECH.

1. INTRODUCTION

Financial managers show their prime concern towards maintaining the firm's financial performance. Of this interest, every financial manager has a core objective to determine and stabilize

the firm's performance. However, the determinants of the financial performance vary with respect to the nature, type, and size of the firm (Capon et al., 1990). Meanwhile, researchers have given a bit attention to the intervening effects of dividend policy on the relationship between the anticipated level of future earnings, stakeholders' interest, Pattern of past dividends, corporate social responsibility, uncertainty, and financial performance. Moreover, this untapped intervening mechanism of dividend policy has been hardly focused on the context of evolving financial markets, even though, these markets contribute their accumulated market share in the development of a global economy. The economy of Pakistan is considered as one of the leading emerging economies, however, this economy has been going through with various challenges. Therefore, CFOs need to study essential factors that might affect the financial performance of their respective firms and this study intend to contribute a crucial mediating mechanism to uplift and overcome the prevailing issues faced by CFOs of listed companies of Pakistan. Kajola et al. (2015) traced out the direct effect of dividend policy and financial performance had been, however, this study located divided policy as an intervening variable between Anticipated level of future earnings, stakeholders' interest, Pattern of past dividends, corporate social responsibility, uncertainty, and financial performance. It is seen that the evidence regarding dividend policy, determinants of dividend policy (like the anticipated level of future earnings, stakeholders' interest, Pattern of past dividends, corporate social responsibility, uncertainty), and financial performance are being well reported. Therefore, it becomes crucial to understand and to contribute a mediating mechanism that might bridge the existing research gap. It is assumed that having appropriate financial analysis and financial forecasting the anticipated level of future earnings may be increased which increases the financial performance. Moreover, holding a good financial performance increases the stakeholders' interest. Adding with that, trend analysis must be done by every stakeholder before to take an active part in the firm, when the patterns of past dividends seemed smoother, the ultimate effect would be created on the financial performance of the firm. Lastly, fully corporate socially responsibly (CSR) may win the confidence of shareholders. In nutshell, all these determinants could be mediated with effective dividend policy. However, it is argued that most of the firm's financial performance is indulged with technical components rather than subjective ones. Here, the technical component is referred to as sales revenue. These determinants are helpful to make a sudden increase in the firm's financial performance, but, in the long-run firms show their position and ability to make persistent dividend payout, which gives the impression of high profitability ratio at firm and investors start believing on the stable financial position of the firm. In this connection, it can be stated that the anticipated level of future earnings, stakeholders' interest, Pattern of past dividends, corporate social responsibility, and uncertainty may not only hold a direct effect on financial performance but the existing relationship between mediated by corporate's dividend policy. Hence, among the core objectives, this study deeply explains the existing relationship determinants of dividend policy and financial performance.

It is ambiguous for financial managers to draw one straight line for the betterment of financial performance. Firms are different and they face different economic challenges. Moreover, firms are restricted to follow certain rules and regulations and need sufficient funds generated from satisfied shareholders. In this regard, once shareholders become satisfied so the willingness to retain and to invest more money will be increased. This refers to a focus on dividend policy and its determinants. The persistent dividend payout keeps the existing shareholders satisfied with the prevailing firm's financial performance. The stable payouts lead to a positive sense among outside investors, and

firms may attract new investments as well. Thus, this study has tapped the burning issue (financial performance) among listed companies (financial and non-financial) of Pakistan. The outcomes of this study give a way forward for financial managers in abstracting certain dividend policy which increases the financial performance.

This study observes the relationship between the anticipated level of future earnings, stakeholders' interest, Pattern of past dividends, corporate social responsibility, uncertainty, and financial performance among listed firms of Pakistan. Moreover, the relationship between the determinants of dividend policy and financial performance through dividend policy is also being the principal purpose of this study.

2. LITERATURE REVIEW

The volatility in the financial environment is turning rapidly. Corporate dividend policy has been reflected as a core element for constructing the upmost corporate financial environment. Globally, the importance of dividend policy is recognized by researchers and financial analysts. During the last decade, researchers have given focus and reviewed extensive theories affecting dividend policy.

2.1 DETERMINANTS OF DIVIDEND POLICY

Lintner (1956) discussed the concept of factors of dividend policy, with the Partial Adjustment Model (PAM). Lintner's behavioral model revealed that aggregate volatility in dividends can be explained as "net payment of dividends (target dividends - dividends outstanding) multiplied with the prevailing percentage of factor adjustment. The dividends payment mainly depends on the income generated during the period. Furthermore, Lintner (1956) considered cash dividends as offline earnings for investors. According to Lintner (1956), stockholders observe a firm's cash flow and believe to invest in, where they gain constant dividends. It is because there could not be a dramatic change in the dividend payment except periodic adjustments (short-term dividend-cuts). Hence, the dividend forecast can be made more appropriately following the PAM model. Fama (1974) documented behavioral models for dividends. In support of Lintner's PAM model, Fama stated that managers give preference to stable and smooth dividend policy and ignore massive expansions in dividend percentages. Fama (1974) and Lintner (1956) reported the firm's earning as a core determinant of dividend policy. Bond and Mougoue (1991) investigated the PAM model among 430 US-based manufacturing firms and found that the PAM model does not fully contain all determinants in abstracting dividend policy. Therefore, they recommended studying more determinants for apt and prompt dividend policy. Baker et al. (1985) and Farrelly et al. (1986) included past dividend patterns and expected future income as key determinants of dividend policy, and when compared to Lintner (1956) PAM model, past dividend patterns and expected future income tend to be more useful in formulating dividend policy.

2.2 ANTICIPATED LEVEL OF FUTURE EARNINGS, STAKEHOLDERS' INTEREST, PATTERN OF PAST DIVIDENDS AND FINANCIAL PERFORMANCE

Friedman and Miles (2006) stated that a firm's management must comprehend itself as concerned parties and overall activities of business must reflect and imitate their needs and interests. Firms should determine stakeholders' interests and contribute activities to satisfy stakeholder's interests, though, it expands financial performance (Mitchell et al., 1997). Freeman (1984) stated that

EMT (Efficient market hypotheses) robustly explain the positive association between stakeholder's perception and financial performance. More the stakeholders' interests lead to more investment that brings more prosperity in the firm and such interests generate a firm's value that is also an integral part of the firm. Meanwhile, a smooth environment must be sustained that reaps the knowledge and skills of stakeholders in improving business performance (Freeman et al., 2004). Furthermore, Freeman (1984) stated that speculators willing to examine prevailing trends to the abstract anticipated level of future earnings. Investors' expectations in forecasting a firm's future earnings work as a key determinant of dividend policy. Hence, investors track past payments of dividends to forecast future earnings (Freeman (1984). Ayuso et al. (2014), Freeman et al. (2004) and Baker et al. (1985) reported positive relationships between the anticipated level of future earnings, stakeholders' interests, patterns of past dividends and financial performance. They revealed having appropriate financial analysis and financial forecasting the anticipated level of future earnings may be increased which increases the financial performance. Moreover, holding a good financial performance increases the stakeholders' interest. Adding with that, trend analysis must be done by every stakeholder before to take an active part in the firm, when the patterns of past dividends seemed smoother, the ultimate effect would be created on the financial performance of the firm.

2.3 UNCERTAINTY AND FINANCIAL PERFORMANCE

There are several concepts regarding "uncertainty", portraying an unclear or unequivocal situation is one mind. This unequivocalness can be about the incongruity of information. In the context of corporate finance, it is considered as financial ambiguity and financial administration needs to reduce the level of uncertainty (Walkup, 2016). The appropriate decline in a firm's uncertainty means the firm has taken defensive measures, and, it can lead to prosperity in dividend payout (Walkup, 2016). Jensen & Meckling (1976) stated that the management of firms thinks about their interest (Managerial interest) rather than the interest of shareholders, so, this conflict may increase the level of uncertainty for shareholders. Additionally, they stated that managerial interests could lead certain increase in financial performance as managers are curious to satisfy their interests (like salary, bonuses, etc.) by protecting the firm from bankruptcy. Hence, financial managers would become efficient to prevent uncertainty. Moreover, Jensen & Meckling (1976) contributed the term "Agency Conflict" which reflects to satisfy managerial interest rather than shareholders. Previously, it had been seen that this agency conflict produces negative effects on payouts. Chay and Suh (2009) revealed that uncertainty in cash flows reduces agency costs and increases investment opportunities. According to walkup (2016) among several determinants of dividend policy, uncertainty is considered as a significant determinant that negatively influences dividend policy and firm performance. Moreover, in a scenario where financial markets become uncertain, simultaneously, firms de-accelerate their financial activities which results in a decline in the firm's financial performance. Dixit et al. (1994) reported a negative effect of uncertainty on the firm's dividend policy. According to Harash et al. (2014), uncertainty leads to slowing down the firm's operation (productivity, etc.) which results in a decline in the firm's profitability and negatively affects financial performance.

2.4 CSR AND FINANCIAL PERFORMANCE

Since the 1970s, discussion regarding corporate social responsibility (CSR) and its relationship with financial performance had in progress. Cochran (1984), Torugsa et al. (2012) showed positive

effects of CSR on financial performance. Van et al. (2008) depicted that CSR is positively observed for financial performance, like value gaining or image building phenomena among people of society, thus, firms having CSR programs gain the attention of society. Van et al. (2008) considered CSR as a promotional activity that increases the positive attitude of consumers towards buying of product/service, thus, there would be an increase in sales and expansions in the firm's profits, thus positively affects firm's dividend policy. Ross (1977) revealed CSR programs give inclination to investors that the firm is financially stable, so, more people start investing in (Signaling concept). Brine et al. (2007) supported that firms that offer CSR programs tend to be less risky. Firms can improve and expand their respective performance by taking necessary initiatives for CSR (Chih et al., 2014). Additionally, they stated that the expenditure incurred on CSR may not affect profitability. The firm's value increases by indulging in CSR activities (Harjoto and Jo, 2015). Dividend policy and performance are positively related to CSR (Hirigoyen and Poulain-Rehim, 2015).

2.5 DIVIDEND POLICY AND FINANCIAL PERFORMANCE

A set of rules and guidelines sustained by firms in distributing dividends among shareholders can be simply referred to as dividend policy (Nissim & Ziv, 2001). The concept regarding dividend policy and financial performance traced through the theoretical contribution of Modigliani & Miller (1961), where they considered dividends policy as an irrelevant factor to determine financial performance, that financial performance is completely independent and not affected by dividends delay or timely payout. However, Amindu (2007) reported a positive relationship between dividend policy and financial performance, and Fakuda (2000) revealed a negative relationship between them. Moreover, (Michaely et al., 2005; DeAngelo et al., 1996) documented the irrelevancy of dividend policy with financial performance and consistent with the concept of M&M (1961). Conversely, recent studies, Kajola et al. (2015); Hoang and Hoxha (2016) reported a positive relationship between payouts and financial performance.

This study proposes a mediating mechanism (which is hardly sparked) of dividend policy between its determinants and financial performance. Figure 1 illustrates the study model and hypotheses, developed following the criteria of Barron & Kenney (1986).

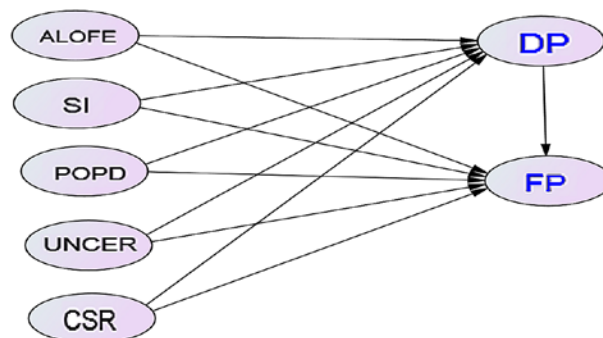

Figure 1: Conceptual Framework (see the abbreviations in Table 1).

2.6 HYPOTHESES DEVELOPMENT

Based on the available literature, the following hypotheses have been developed in this study.

- H₁: Anticipated level of future earnings has a significant and positive effect on financial performance.*
- H₂: Stakeholders' interest has a significant and positive effect on financial performance.*
- H₃: Patterns of past dividends have a significant and positive effect on financial performance.*

- H₄: Uncertainty has a significant and negative effect on financial performance.*
- H₅: Corporate social responsibility has a significant and positive effect on financial performance.*
- H₆: Anticipated Level of future earnings has a significant and positive effect on dividend policy.*
- H₇: Stakeholders' interests have a significant and positive effect on dividend policy.*
- H₈: Patterns of past dividends have a significant and positive effect on dividend policy.*
- H₉: Uncertainty has a significant and negative effect on dividend policy.*
- H₁₀: Corporate social responsibility has a significant and positive effect on dividend policy.*
- H₁₁: Dividend policy has a significant and positive effect on financial performance.*
- H₁₂: Dividend policy mediates between the anticipated Level of future earnings and financial performance.*
- H₁₃: Dividend policy mediates between stakeholders' interests and financial performance.*
- H₁₄: Dividend policy mediates between patterns of past dividends and financial performance.*
- H₁₅: Dividend policy mediates between uncertainty and financial performance.*
- H₁₆: Dividend policy mediates between corporate social responsibility and financial performance.*

2.7 DATA AND METHODOLOGY

2.7.1 NATURE & TYPE OF RESEARCH

This study investigates the effects of determinants of dividend policy on financial performance among the listed firms of Pakistan. Thus, it is considered as causal in nature. In terms of research type, it is quantitative and based on primary data which is cross-sectional. This study has behavioral perspectives. Therefore, it is based on a cross-sectional survey method through questionnaires,

2.7.2 DATA SOURCES, POPULATION & SAMPLE

In this regard, behavioral responses have taken from Chief financial officers (CFOs) of listed manufacturing firms of Pakistan. The population frame includes CFOs of different financial and non-financial sectors such as Banking, Insurance, Telecommunication, Automobile, Cement, Fertilizer, Oil and Gas, Sugar, Textile, Tobacco, Pharmaceutical, out of 280 questionnaires distributed among these companies only ($N=232$) were used in the study. Hence, sample size 232 is good enough to perform SEM as the required sample size should be >200 (Nachtigall et al., 2003).

2.7.3 RESEARCH INSTRUMENTS

Being a survey-based, the adopted and modified questionnaire (five-point Likert Scale) was used for determinants of dividend policy, dividend policy, and financial performance. The reliability (internal consistency) of the instrument was determined through Cronbach's alpha. Table 1, it is seen that reliability has been established for all constructs' scales. Moreover, the validity of scales will be examined while testing the measurement part of the SEM. Table 1, all Alpha scores are >0.70 , all constructs are thus considered reliable.

Table 1: Research Instrument & Reliability Score

Constructs	Items	Alpha Score
Anticipated Level of Future Earning (ALOFE)	4	.82
Stakeholders' Interest (SI)	5	.78
Patterns of Past Dividends (POPD)	6	.74
Uncertainty (UNCER)	5	.80
Corporate Social Responsibility (CSR)	6	.77
DividendPolicy (DP)	4	.72
Financial Performance (FP)	5	.87

3. RESULT AND DISCUSSION

3.1 DESCRIPTIVE STATISTICS

Table 2 shows respondents' profile which includes age, experience, marital status, and gender. The response from the age group of 36-50 years was largely observed with a frequency of 144 (62%). Experience shows that majority of respondents (Frequency=164, Percent=71%) were from 5-10 years of managerial experience. Most respondents were married and in terms of gender classification, most were male.

Table 2: Respondents' Profile.

Demographics	Categories	Frequency	Percent
Age (years)	30 to 35	38	16
	36 to 50	144	62
	50 and above	50	22
Experience (years)	5 to 10	164	71
	11 to 20	68	29
Marital Status	Single	78	34
	Married	154	66
Gender	Male	192	83
	Female	40	17

3.2 STRUCTURAL EQUATION MODELLING (SEM)

This study has used a significant and comprehensive approach that reconciles to objectives and hypotheses of this study. This robust approach is *Structural Equation Modelling* (SEM), for a large sample size ($N > 200$). This study has used the two-step CB-SEM approach (Covariance-based SEM). The covariance or measurement part (1st step) is examined to establish validities and hypotheses will be assessed through structural analysis (2nd step) (Prabhu, 2007; Nachtigall, 2003). Confirmatory Factor Analysis (CFA) has been performed for validities.

3.2.1 CFA OUTCOMES

Figure 2 demonstrates the results of the CFA (modified) model. This model shows factor loading $> .50$ and low intercorrelations (covariance) $> .40$ among latent constructs (Cua et al., 2001). CFA analysis confirms that chosen items for each construct intend to explain the same construct, and items being validated through convergent validity, where, AVE and CR of each construct fall under the recommended threshold. However, some items were removed and followed modification indices to improve the goodness of fit of the model. In this regard, predictive fit (chi-square), comparative fit (Comparative Fit Index (CFI), Tucker-Lewis Index (TLI)), and other fits such as Goodness of Fit Index (GFI), adjusted goodness of fit index (AGFI), and root mean square error of approximation (RMSEA) explained suitable model fitness. Moreover, it is seen that discriminant validity is also justified as criteria suggest that correlation (r^2) should not be more than AVE of each pair of latent constructs (Fornell & Larcker, 1981). Figure 2 shows very small intercorrelations among latent constructs, hence, discriminant validity confirms that each construct has sole-identity and not much covariance with other constructs, thus, discriminant validity was established (Keramati et al., 2010). Furthermore, the p-value of every item of a particular factor was observed below $< .05$ or $.01$ level of significance. Therefore, nomological validities were also proved.

ALOFE	SI	POPD	UNCER	CSR	FP	DP
.783	.725	.751	.729	.783	.748	.703 = AVE
.915	.913	.937	.931	.947	.922	.904 = CR

Criteria:
 If AVE score >.50
 If CR >.70
 Fornell & Larcker, (1981)

Fit Indices
 CMIN/DF=2.64
 GFI=.970
 AGFI=.960
 TLI=.950
 CFI=.990
 RMSEA=.052

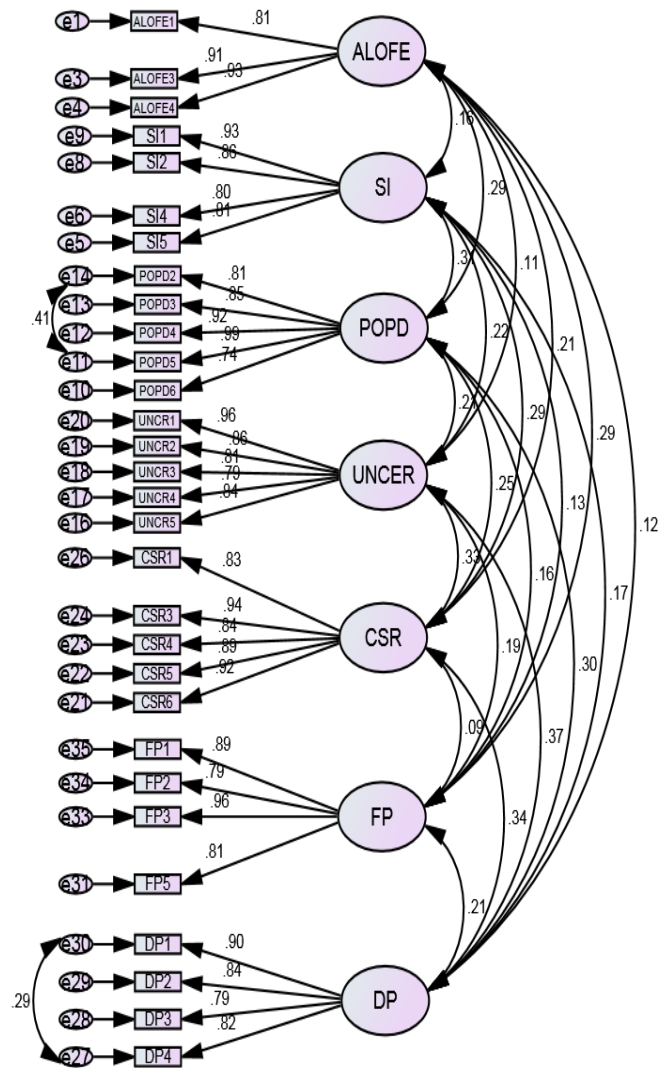

ALOFE= Anticipated level of future earnings, SI= Stakeholders' Interest, POPD= Patterns of past of dividends, UNCER= Uncertainty, DP= Dividend Policy, FP= Financial Performance

Figure 2: CFA (Modified).

Table 3: Convergent Validity (Fornell & Larcker, (1981)).

Criteria	ALOFE	SI	POPD	UNCER	CSR	FP	DP
If AVE score >.50	.783	.725	.751	.729	.783	.748	.703
If CR >.70	.915	.913	.937	.931	.947	.922	.904
	Proved	Proved	Proved	Proved	Proved	Proved	Proved

3.2.2 SEM OUTCOMES

Figure 3 reveals the results of the structural model. Anticipated level of future earnings has a significant and positive effect on financial performance or it can be stated that a 1% change in anticipated level of future earnings can generate or 62% positive impact on financial performance, hence, **H1** was retained. Further, the path coefficient for stakeholders' interest and financial performance shows the significant and positive effect with (b=.48, p=.01), these results are consistent to retain **H2**. Patterns of past dividends have a significant and positive impact on financial performance (b=.39, p=<.05), thus, **H3** was accepted. Uncertainty → Financial performance revealed (b=.57, p=.31), thus, **H4** was failed to retain. However, Corporate social responsibility is significantly and positively influenced on financial performance by (b=.62, p=.01) respectively. Therefore, **H5** has been retained. Meanwhile, Path-C was significantly observed (under .05 or =.01 level of significance) for all latent constructs (except uncertainty → financial performance) and fit indices shows apt

goodness of fit of the model (McAulay et al., 2006; Roh et al., 2005; Hair et al.,1998).

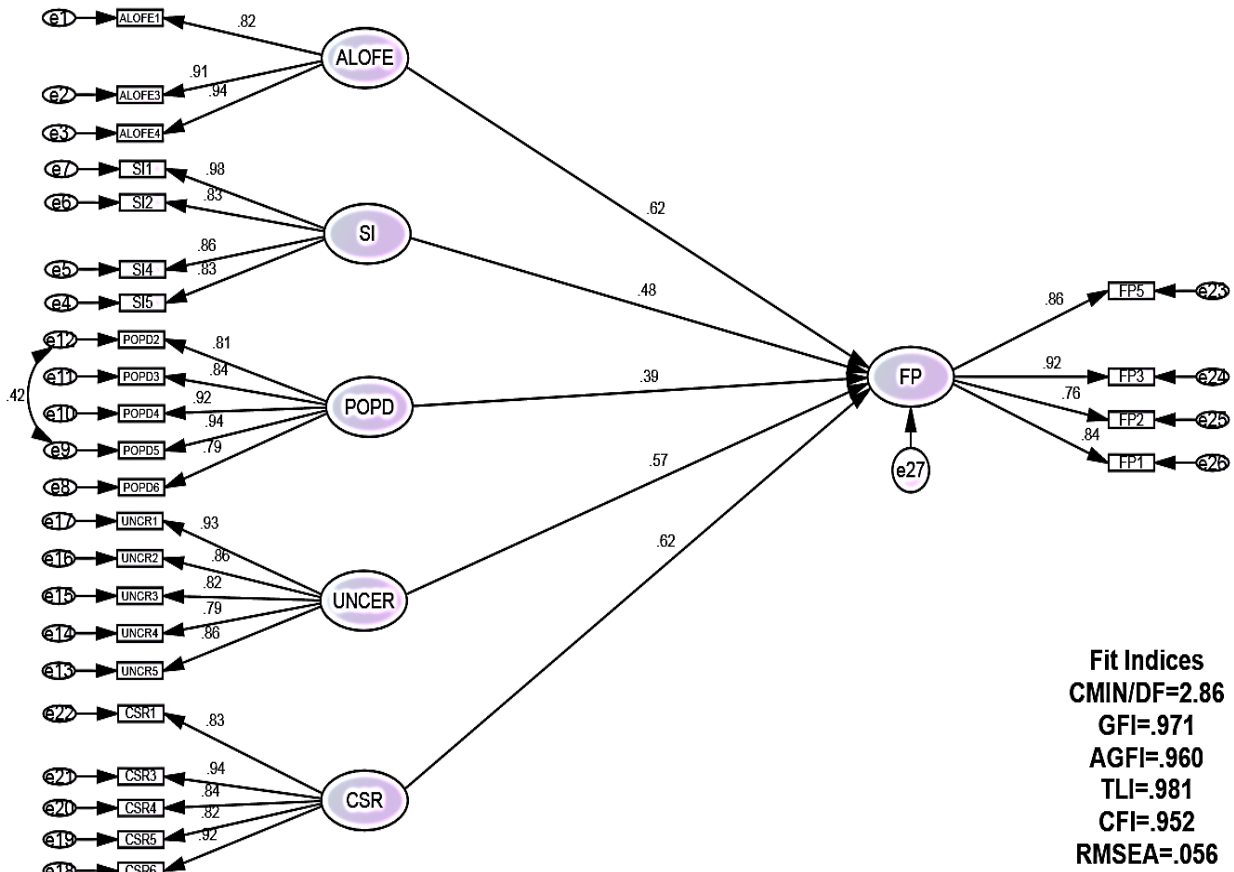

Figure 3: Structural Part (1st order) of SEM (Path-C Analysis).

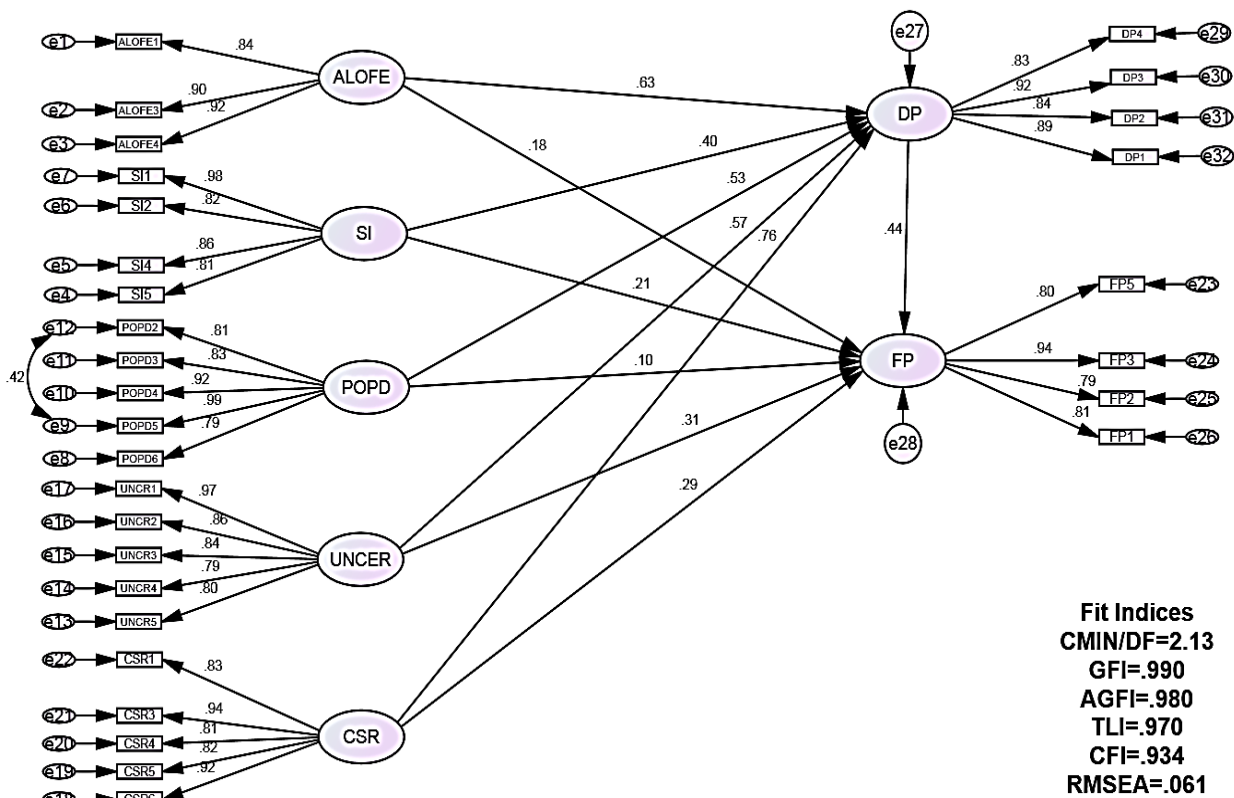

Figure 4: Structural Part (1st order) of SEM (Path- A, Path-B, and Path-C').

Figure 4 shows the results for Path-A, Path-B, and Mediating effect (Path-C'). It was observed that the anticipated level of future earnings has a significant and positive effect on DP ($b=.63, p<.05$), hence, **H6** was retained. Furthermore, path-A demonstrates stakeholders' interest and dividend policy that shows the significant and positive effect with ($b=.40, p=.01$), these results are in line to retain **H7**. For **H8**, patterns of past dividends have a significant and positive impact on dividend policy ($b=.53, p=.01$). Uncertainty and corporate social responsibility are also significantly and positively influence dividend policy by ($b=.57, p=.01$) and ($b=.76, p<.05$) respectively. Therefore, **H10** has been retained and **H9** was failed to retain because it was proposed that uncertainty \rightarrow dividend policy is negatively related. Meanwhile, Path-A was significantly observed (under .05 or =.01 level of significance) for all latent constructs along with suitable fit indices. Path-B, dividend policy \rightarrow financial performance was significantly and positively observed, based on results ($b=.44, p=.01$) **H11** was stand accepted. Now, moving ahead to determine the mediating effect of dividend policy on the relationship between the anticipated level of future earnings, stakeholders' interest, patterns of past dividends, uncertainty, corporate social responsibility, and financial performance, Path-C' was observed. Path, anticipated level of future earnings \rightarrow dividend policy \rightarrow financial performance (C') shows ($b=.18, p=.301$), previously, it was significantly observed, as dividend policy inducted as mediator the path anticipated level of future earnings \rightarrow financial performance became insignificant and confirms that dividend policy mediates the relationship between the anticipated level of future earnings and financial performance (**H12** was retained). In the same manner, stakeholders' interest \rightarrow dividend policy \rightarrow financial performance (C') revealed ($b=.21, p=.410$) which confirms **H13** and stated as dividend policy mediates the relationship between stakeholders' interest and financial performance. Moreover, a path like the pattern of past dividends \rightarrow dividend policy \rightarrow financial performance (C') and uncertainty \rightarrow dividend policy \rightarrow financial performance (C') shows ($b=.10, p=.210$) and ($b=.31, p=.010$) which confirm **H15**. However, the mediating effect for **H14** is not useful because it had not qualified or significantly observed among path-c and path-a as suggested by Barron & Kenney (1986). Lastly, it was observed that dividend policy does not mediate the relationship between corporate social responsibility and financial performance, the path outcomes for corporate social responsibility \rightarrow dividend policy \rightarrow financial performance (C') revealed ($b=.29, p=.021$), it was observed that intervening emphasis of a dividend policy does not help to mediate the relationship of corporate social responsibility \rightarrow financial performance and it also at significant ($p=.021$). Hence, **H16** was failed to retain. Meanwhile, the results of the structural model were in line with the studies of Bae, Kang, and Wang (2011), Ittner and Larcker (2001), Chih et al. (2014), Niazi et al. (2011) and Freeman et al. (2004).

4. CONCLUSION

The main objective of this study was to identify the behavioral perspective and mediating mechanism of dividend policy on the relationship between determinants of dividend policy (Anticipated Level of Future Earnings, Stakeholders' Interest, Patterns of Past Dividend, Uncertainty, and Corporate Social Responsibility) and financial performance among CFOs of different financial and non-financial sectors such as Banking, Insurance, Telecommunication, Automobile, Cement, Fertilizer, Oil and Gas, Sugar, Textile, Tobacco, Pharmaceutical. The rationale behind observing this particular set of variables was to confirm the possible causes that solve issues regarding financial performance. In this connection, determinants of dividend policy worked as an independent variable

and dividend policy a mediating variable between its determinants and financial performance. The primary data was collected, and the survey method was used to collect responses from CFOs of Pakistani financial and non-financial firms. The collected data was analyzed through SEM statistical approach. The outcomes revealed that dividend policy mediates the relationship between its' determinates (Anticipated Level of Future Earnings, Stakeholders' Interest, Patterns of Past Dividend, Uncertainty, and Corporate Social Responsibility) and financial performance except for uncertainty and corporate social responsibility. The research is helpful for financial managers in formulating dividend policy and to have better financial performance. Moreover, this study is also essential for stakeholders associated with companies.

5. AVAILABILITY OF DATA AND MATERIAL

Data can be made available by contacting the corresponding author.

6. REFERENCES

- Amidu, M. (2007). How does dividend policy affect the performance of the firm on Ghana Stock Exchange? *Investment Management and Financial Innovations*, 4(2), 103-112.
- Ayuso, S., Rodríguez, M.A., García-Castro, R., & Arino, M.A. (2014). Maximizing stakeholders' interests: An empirical analysis of the stakeholder approach to corporate governance. *Business & Society*, 53(3), 414-439. DOI: 10.1177/0007650311433122
- Bae, K.H., Kang, J.K., & Wang, J. (2011). Employee treatment and firm leverage: A test of the stakeholder theory of capital structure. *Journal of Financial Economics*, 100(1), 130-153. DOI: 10.1016/j.jfineco.2010.10.019
- Baker, H.K., Farrelly, G.E., Edelman, R.B. (1985). A Survey of Management Views on Dividend Policy. *Financial Management*, 14(3), 78-84.
- Bond, M.T., Mougoue, M. (1991). Corporate Dividend Policy and the Partial Adjustment Model. *Journal of Economics and Business*, 43(2), 165-178.
- Brine, M., Brown, R., & Hackett, G. (2007). Corporate social responsibility and financial performance in the Australian context. *Economic Round-Up*, 2, 47-58.
- Capon, N., Farley, J.U., & Hoenig, S. (1990). Determinants of financial performance: A meta-analysis. *Management Science*, 36(10), 1143-1159. DOI:10.1287/mnsc.36.10.1143
- Chay, J.B., & Suh, J. (2009). Payout policy and cash-flow uncertainty. *Journal of Financial Economics*, 93(1), 88-107. DOI: 10.1016/j.jfineco.2008.12.001
- Chih, H.H., Miao, W.C., & Chuang, Y.C. (2014). Is corporate social responsibility a double-edged sword? Evidence from fortune global 500 companies. *Journal of Management*, 31(1), 1-19.
- Cochran, P.L., & Wood, R.A. (1984). Corporate social responsibility and financial performance. *Academy of Management Journal*, 27(1), 42-56.
- Cua, K.O., McKone, K.E., & Schroeder, R.G. (2001). Relationships between the implementation of TQM, JIT, and TPM and manufacturing performance. *Journal of Operations Management*, 19(6), 675-694. DOI: 10.1016/S0272-6963(01)00066-3
- DeAngelo, H., DeAngelo, L., & Skinner, D. J. (1996). Reversal of fortune dividend signaling and the

- disappearance of sustained earnings growth. *Journal of Financial Economics*, 40(3), 341-371. DOI: 10.1016/0304-405X(95)00850-E
- Dixit, A.K., Dixit, R.K., Pindyck, R.S., & Pindyck, R. (1994). *Investment under uncertainty*. Princeton University Press.
- Fama, E.F. (1974). The Empirical Relationship Between the Dividend and Investment Decisions of Firms. *American Economic Review* 64(3), 304-318.
- Farrelly, G.E. and Baker, H.K. 1989, Corporate Dividends: Views of Institutional Investors. *Akron Business and Economic Review* 20(2), 89-100.
- Farrelly, G.E., Baker, H.K., Edelman, R.B. (1986). Corporate Dividends: Views of the Policymakers. *Akron Business and Economic Review*, 17(4), 62-74.
- Fornell, C., & Larcker, D.F. (1981). Evaluating structural equation models with unobservable variables and measurement error. *Journal of Marketing Research*, 18(1), 39-50. DOI:10.1177/002224378101800104
- Freeman, R.E. (1984). *Strategic management: A stakeholder approach*. Boston, MA: Pitman.
- Freeman, R.E., Wicks, A.C., & Parmar, B. (2004). Stakeholder theory and the corporate objective revisited. *Organization Science*, 15(3), 364-369. DOI: 10.1287/orsc.1040.0066
- Friedman, A.L., & Miles, S. (2006). *Stakeholders: Theory and practice*. Oxford University Press.
- Fukuda, A. (2000). Dividend changes and earnings performance in Japan. *Pacific-Basin Finance Journal*, 8(1), 53-66. DOI: 10.1016/S0927-538X(99)00024-4
- Ghosh, C. and J.R. Woolridge, (1988). An Analysis of Shareholder Reaction to Dividend Cuts and Omissions. *Journal of Financial Research*, 11(4), 281-294.
- Grullon, G., Michaely, R., Benartzi, S., & Thaler, R.H. (2005). Dividend changes do not signal changes in future profitability. *The Journal of Business*, 78(5), 1659-1682. DOI: 10.1086/jb.2005.78.issue-5
- Hair, J.F., Anderson, R.E., Tatham, R.L., & Black, W.C. (1998). *Multivariate data analysis*. 5th Ed., Prentice-Hall.
- Harash, E., Alsaadi, J., & Al-Timimi, S. (2014). Financial performance of SMEs - Evidence on the influence of environmental uncertainty: A conceptual framework. *China-USA Business Review*, 13(8), 540-545.
- Harjoto, M.A., & Jo, H. (2015). Legal vs. normative CSR: Differential impact on analyst dispersion, stock return volatility, cost of capital, and firm value. *Journal of Business Ethics*, 128(1), 1-20. DOI: 10.1007/s10551-014-2082-2
- Hirigoyen, G., & Poulain-Rehim, T. (2015). Relationships between corporate social responsibility and financial performance: What is the causality? *Journal of Business and Management*, 4(1), 18-43.
- Hoang, E. C., & Hoxha, I. (2016). Corporate payout smoothing: A variance decomposition approach. *Journal of Empirical Finance*, 35, 1-13. DOI: 10.1016/j.jempfin.2015.10.011
- Ittner, C.D., & Larcker, D.F. (2001). Assessing empirical research in managerial accounting: A value-based management perspective. *Journal of Accounting and Economics*, 32(1-3), 349-410. DOI: 10.1016/S01654101(01)00026-X

- Jensen, M.C., & Meckling, W.H. (1976). Theory of the firm: Managerial behavior, agency costs and ownership structure. *Journal of Financial Economics*, 3(4), 305-360. DOI: 10.1016/0304-405X(76)90026-X
- Kajola, S.O., Adewumi, A.A., & Oworu, O.O. (2015). Dividend pay-out policy and firm financial performance: Evidence from Nigerian listed non-financial firms. *International Journal of Economics, Commerce and Management*, 3(4), 1-12.
- Keramati, A., Mehrabi, H., & Mojir, N. (2010). A process-oriented perspective on customer relationship management and organizational performance: An empirical investigation. *Industrial Marketing Management*, 39(7), 1170-1185. DOI: 10.1016/j.indmarman.2010.02.001
- Lintner, J. (1956). Distribution of Incomes of Corporations Among Dividends, Retained Earnings and Taxes. *American Economic Review*, 46(2), 97-113.
- McAulay, B.J., Zeitz, G., & Blau, G. (2006). Testing a push pull theory of work commitment among organizational professionals. *The Social Science Journal*, 43(4), 571-596. DOI: 10.1016/j.soscij.2006.08.005
- Miller, M. H., & Modigliani, F. (1961). Dividend policy, growth, and the valuation of shares. *The Journal of Business*, 34(4), 411-433.
- Mitchell, R.K., Agle, B.R., & Wood, D.J. (1997). Toward a theory of stakeholder identification and salience: Defining the principle of who and what really counts. *Academy of Management Review*, 22(4), 853-886. DOI: 10.5465/amr.1997.9711022105
- Nachtigall, C., Kroehne, U., Funke, F., & Steyer, R. (2003). Pros and cons of structural equation modeling. *Methods Psychological Research Online*, 8(2), 1-22.
- Netemeyer, R.G., Bearden, W.O., & Sharma, S. (2003). *Scaling procedures: Issues and applications*. Sage Publications.
- Niazi, G.S.K., Hunjra, A.I., Rashid, M., Akbar, S.W., & Akhtar, M.N. (2011). Practices of working capital policy and performance assessment financial ratios and their relationship with organization performance. *World Applied Sciences Journal*, 12(11), 1967-1973.
- Nissim, D., & Ziv, A. (2001). Dividend changes and future profitability. *The Journal of Finance*, 56(6), 2111-2133. DOI: 10.1111/0022-1082.00400
- Prabhu, N.U. (2007). *Stochastic processes: Basic theory and its applications*. Macmillan New York.
- Roh, T.H., Ahn, C.K., & Han, I. (2005). The priority factor model for customer relationship management system success. *Expert Systems with Applications*, 28(4), 641-654. DOI: 10.1016/j.eswa.2004.12.021
- Ross, S.A. (1977). The determination of financial structure: The incentive-signalling approach. *The Bell Journal of Economics*, 8(1), 23-40. DOI: 10.2307/3003485
- Steenkamp, J.B.E., & Baumgartner, H. (2000). On the use of structural equation models for marketing modeling. *International Journal of Research in Marketing*, 17(2-3), 195-202. DOI: 10.1016/S0167-8116(00)00016-1
- Torugsa, N.A., O'Donohue, W., & Hecker, R. (2012). Capabilities, proactive CSR and financial performance in SMEs: Empirical evidence from an Australian manufacturing industry sector. *Journal of Business Ethics*, 109(4), 483-500. DOI: 10.1007/s10551-011-1141-1

Van Beurden, P., & Gössling, T. (2008).The worth of values-A literature review on the relation between corporate social and financial performance. *Journal of Business Ethics*, 82(2), 407. DOI: 10.1007/s10551-008-9894-x

Walkup, B. (2016). The impact of uncertainty on payout policy. *Managerial Finance*, 42(11), 1054-1072. DOI: 10.1108/MF-09-2015-0237



S.A Bhutto is a PhD Scholar at the Institute of Commerce, Shah Abdul Latif University, Pakistan. He got his M.Phil in Corporate Finance from SALU Kahirpur, Pakistan. His researches are mainly on Corporate Finance, Investments, Financial Markets, Portfolios, Behavioral Finance, Econometrics, and some on HRM.



Dr. Hassan Jawad Soomro is a Professor at Institute of Commerce, Shah Abdul Latif University, Pakistan. He got his Ph.D. in Consumer Behaviour Marketing from SALU Kahirpur, Pakistan. His research focuses on Behavioral fields like customers' psychology and Behavioral Finance.



Dr. Saifullah Shaikh is an Assistant Professor at Institute of Commerce, Shah Abdul Latif University, Pakistan. He recently earned Ph.D. in HRM from SALU Kahirpur, Pakistan. His research focuses on Behavioral fields like Occupational Psychology.



Dr. Hussain Amar is a Lecturer at Govt. Islamia Arts & Commerce College, Sukkur. He got his PhD in HRM from SALU Khairpur, Pakistan. His core research interest is Behavioral Sciences.



Dr. Qamar Abbas Mangi works at Institute of Commerce, Faculty of Management Sciences, Shah Abdul Latif University, Pakistan. He completed his Ph.D. in HRM from SALU Kahirpur, Pakistan. His Key research interests are in Behavioral fields.
