



PAPER ID: 11A14C



APPLICATIONS OF FEED PUSHER ROBOTS ON CATTLE FARMINGS AND ITS ECONOMIC EFFICIENCY

V.I. Nabokov¹, L.A. Novopashin¹, L.V. Denyozhko¹, A.A. Sadov^{1*},
N.V. Ziablitchkaia², S.A. Volkova¹, I.V. Speshilova³

¹ Department of Management and Law, Federal State Budgetary Educational Establish of Higher Education «Ural State Agrarian University» (FGBOU VO Uralsky GAU) Ekaterinburg, Karl Liebknecht ul., 42, 620075, RUSSIA.

² Faculty of Economics and Management, South Ural State University, Chelyabinsk, pr.Lenina, 76, 454080, RUSSIA.

³ Department of Economics and Management, Orenburg branch of the Federal State Budgetary Institution of Science of the Ural Branch of the Russian Academy of Science, Orenburg. ul.Pionerskaya. d.11, 460000 Russian Federation, RUSSIA.

ARTICLE INFO

Article history:

Received 06 January 2020
Received in revised form 06
May 2020
Accepted 01 July 2020
Available online 03 August
2020

Keywords:

Animal Farming;
Livestock farming;
Robotic application;
Robot Trimmer; Robotic
farming investment;
Cattle feeding.

ABSTRACT

Currently, robotics is used in various branches of agriculture. This study's main objective is to identify benefits and assess the economic efficiency of using robotics in cattle feeding. The robot feed pusher was tested in the Middle Urals. The feed pusher refers to agricultural robots, it has a body, track rollers, reversible DC drives, a control unit, and other elements, designed to move on the farm along the feed passage, while moving and mixing the feed into a homogeneous mass. The main advantages of using the food pusher robot are saving labour costs, increasing animal productivity, reducing feed losses as a result of irregular consumption by animals. The total economic effect of using the food pusher robot is 1,435.6 thousand rubles per year with a return on investment of 87.8%, and a payback period is 407 days. Limitations for the mass use of these robots may be the lack of free cash assets at farmers to introduce these robots, poor development or lack of rural infrastructure, and the possible unwillingness of workers to its introduction. The use of a feed pusher in cattle feeding has several undeniable advantages that expect an increase in the use of this type of robotics.

Disciplinary: Agriculture Economic, Feeding Technology.

©2020 INT TRANS J ENG MANAG SCI TECH.

1. INTRODUCTION

Currently, the greatest niche of agricultural robotics is milking robotics. The market is growing significantly in the segment of unmanned aerial vehicles that monitor and process agricultural lands.

In the nearest future, the demand for robots to replace humans in operations with a high proportion of monotonous, hard hand labour: selective processing of crops, harvesting, etc. will increase. At the same time, the use of robotic feed pushers for feeding animals is gaining popularity.

The process of making feed and foddering is one of the most labour-intensive operations at cattle breeding farms and, according to various estimates, requires from 25% (Grothmann et al., 2010; Pezzuolo et al., 2016) to 40% (Kupreenko et al., 2014) of working time. To automate the process of making feed and foddering at cattle farms, automatic feeding systems are introduced (Kupreenko et al., 2018; Morozov and Rasskazov, 2019), including feed pusher. One key advantage of automatic feeding systems is the possibility of a significant increase in the frequency of feeding up to 8 times or more per day (Bisaglia et al., 2012), reduction of feed loss as a result of uneven consumption, etc. (Katkov et al., 2019). Some studies concern observation of the influence of this parameter on the animal's behaviour, their productivity, and other physiological indicators (Grothmann et al., 2014; Mattachini et al., 2019). The use of robotics in agriculture (Morozova, 2017) will significantly increase the level of competitiveness of this industry (Voronin et al., 2019; Latvietis et al., 2013).

2. MATERIAL AND METHODS

The object of the study was one of the agricultural organizations of the Sverdlovsk Region OOO «Yamovsky» of the Alapayevsky area of the Sverdlovsk Region, where the technology of loose keeping and robotic milking of the cattle was introduced. The subject of the study is the economic efficiency of using a feed pusher.

The studies were carried out directly in the livestock barn, where animals are kept and a feed pusher robot is used. The study group included 200 cows. The average weight of one animal was 570 kg, while the milk yield per head reached 6800-7300 kg per lactation. In summer and winter, the feeding of the cattle did not differ and corresponded to the norms, while the fluctuation in milk yield in some months was insignificant, 24-27 kg per day.

In a barn with robotics, the cattle got the main feed in a form of a feed mixture, it consisted of 85% rough and succulent grass feeds: including corn silage, hay from perennial grasses, and a small amount of hay; in summer, the green mass of perennial grasses were used. A mixture of concentrates made at the farm, including barley, molasses, salt and other additives had 10% in the feed mixture. Depending on productivity, the cattle got commercial feed in the form of granules, which was fed automatically in robotic milking.

The main objective of the study is to identify prospects and assess the economic efficiency of the use of robotics in feeding the cattle.

The following research tasks can be distinguished:

- 1) revealing the basic elements and the principle of applying the feeding robot-leveler;
- 2) determining the strengths of using a feed pusher robot in comparison to traditional technologies;
- 3) assessing the economic efficiency of the use of robotics in feeding based on the results of its use on the farm;
- 4) clarifying prospects and identifying restrictions in the use of a feed pusher in feeding the cattle.

The economic-statistical and comparative analysis were used as general economic methods, a systematic approach, as well as other methods of scientific research, generalization and information processing, due to specific tasks of scientific work, were also used.

3. RESULTS AND DISCUSSION

As of January 1, 2018, robotics in agriculture was used in 29 regions of the country by more than 110 organizations, primarily in the milk-and-food sector. According to the Ministry of Agriculture and Food of the Sverdlovsk Region, as of January 1, 2019, 42 milking robotic units and two feed pushers were installed and used. The most intensive introduction of robotics in the Russian Federation was in 2014, however, later the pace of its introduction slightly decreased by 10.7% and 21.3% in 2015 and 2016, respectively. This was since all robotics used in the Russian Federation are of foreign manufacturers, and due to the changes in the exchange rate and the price rising of this equipment, it became too expensive for many agricultural organizations.

The Lely Juno feed pusher of the Dutch company Lely, used at OOO «Yamovsky», is designed for use on livestock farms (cowsheds) with a feed fence of 102 x 4.5 meters. The robot is adapted to any barn, with the ability to work in several rooms at once, on the outdoor concrete floor (Figure 1).

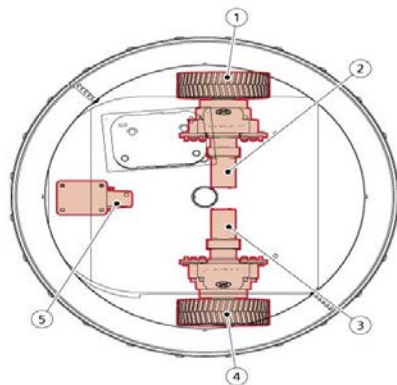

1. Left track roller
2. The engine of the left basic skating rink
3. Right support katov
4. Engine right track roller
5. Front track roller

Figure 1: Sketch of the feed trimmer robot (top view).

The feed pusher is powered by rechargeable batteries (on lead batteries: 2 low-voltage 12V batteries) and after each cycle of work, it returns to the charging station, which is installed in an accessible place at the feed alley. The charging station should be a 220/10 V (DC) power supply unit designed to recharge the robot batteries from an external network of 220V AC (Figure 2).

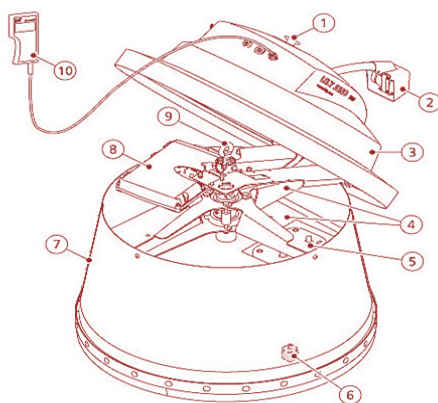

1. Emergency stop button
2. Charger
3. Hinged cover
4. Gyroscope
5. Charging battery
6. Track roller engine
7. Case
8. Gyroscope
9. Charger
10. E-link manual control panel

Figure 2: Sketch of the feed trimmer robot (side view)

The main function of the feed-pusher is moving and simultaneous mixing the feed into a homogeneous mass on a feed table at a predetermined distance from the stalls to ensure proper access for animals to the feed. The robot must independently move and mix the animal feed 10-12 times a day into a homogeneous mass. There is a function of the safe movement of the robot (non-contact security system). The robot stops at a distance of 30-50 cm from the obstacle. It uses a distance sensor

(sonar/sonar) on its front side. The reverse side and lateral sides are equipped with contact sensors that allow various maneuvers (Figure 3).

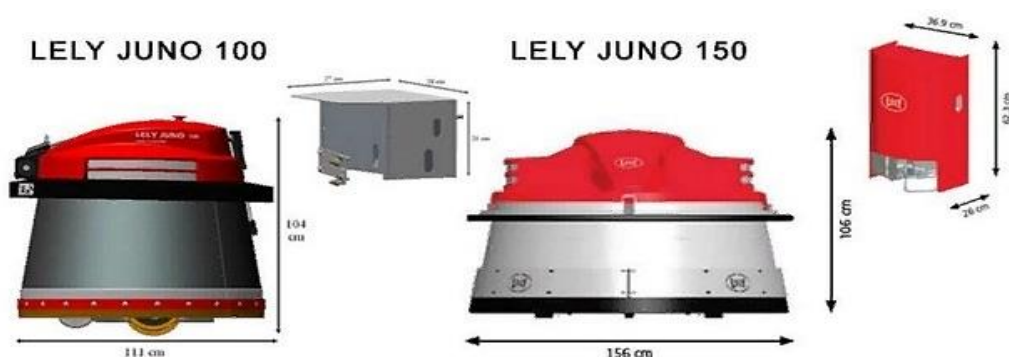

Figure 3: Lely Robot Trimmer in kind

The Lely Juno battery feed pusher is suitable for any hard and smooth feed tables and can move along any feed fences. This robot model disadvantage is it can move only on a solid, smooth concrete floor with or without coating. Also, the floor should have a limited slope. Also, there is a risk of rutting on a bitumen pavement when it is used outside the barn in warm and hot weather. Another disadvantage is the significant amortization of the track rollers. A serious disadvantage also involves failures during movement due to the loss of orientation of the robot in the space.

Determining the efficiency of using robotics in agriculture can be carried out based on measuring the particular effects of its use. Thus, the annual economic effect of using a feed pusher robot (E_{fp}) consists of the sum of the particular effects resulting from its use:

$$E_{fp} = E_{pr} + E_{sf} + E_{lc} - \Delta A_{rp} - O_{st} \quad (1)$$

where

E_{pr} – the effect of the increase in the value of the products received, rub.;

E_{sf} – the effect of saving feed, rub.;

E_{lc} – the effect of saving labour costs, rub.;

ΔA_{rp} – changes of depreciation charges, rub.;

O_{st} – the cost of services of third-party organizations for maintenance of robotics, rub.

Moreover, to determine the annual economic effect of the use of this equipment, it is possible to use the above-mentioned approach (Table 1).

Table 1: The economic efficiency of the use of a feed-pusher

Type of efficiency	Amount, rubles
The effect of increasing productivity, thous. rubles	172,4
The effect of reducing feed losses, thous. rub.	923,0
Saving on the payroll for the year, thous. rub	340,2
The total economic outcome, thous. rub.	1435,6
Return on investment, %	87,8
Payback period, days	407,0

The calculations allow making the following conclusions. The reduction in feed losses 3.5-13%, while the unused feed cost decreases from 1214 to 294 thousand rubles. The total economic effect of reducing feed losses is 923 thousand rubles per year. The savings in the workers' wages will be up to 340.2 thousand rubles per year. The effect of increasing labour productivity will be 172.4 thousand rubles. The calculations show that the total economic outcome is 1,435.6 thousand rubles per year with the return on investment 87.8%, and the payback period is 407 days. Table 2 identifies the prospects and limitations of the use of feed-pushers.



Figure 4: LELY JUNO Automatic feed pusher (Courtesy of Lely.com).

Table 2: SWOT analysis of the use of feed-pushers.

Strengths	Weaknesses
Increase in animal productivity	Lack of available cash assets for the introduction of feed pushers
Savings in payment for labour	Weak development or lack of the infrastructure
The decrease in feed losses as a result of irregular consumption by animals	Possibility of the unwillingness of workers to use
Opportunities	Threats
Availability of subsidies by the state for purchasing robots, feed-pushers	Apparent lag in introduction pace and research of robotics for agriculture
Additional work in a highly-technological sector including programming & maintenance of robotics	Possibility of rising unemployment in rural areas with hand, unskilled labour
A decrease of hand unskilled labour in agriculture	Poor awareness of farmers about the capabilities of robots

The purchase of robots - feed pushers in the Russian Federation is subsidized by the state, that is, part of the cost for installation and payment to dealers is returned to the farmer. To support the farmers, a strategy for the scientific and technological development of the Russian Federation until 2030 was adopted, one of its priorities is the transition within the next 10-15 years to digital, intelligent production technologies, robotic systems. This increases the possibility of further buying this machinery. A further increase in the number of used leveling robots feed-pushers will contribute to making additional workplaces in a high-tech sector, including programming, and maintenance of robotics. Finally, this can lead to a decrease in hand unskilled labour in agriculture.

A significant threat for Russia is an apparent lag in scientific and technical development and research of robotics for agriculture. The solution to this problem may be joint organizations with foreign partners. The total use of robotics in the industry can increase the possibility of rising unemployment in rural areas with hand, unskilled labour. According to some forecasts, robotics, including in agriculture, could increase technological unemployment. This is especially true for the agrarian sector, where a significant proportion of the rural population is involved. It is necessary to identify the most vulnerable types of activities, which will allow formulating scientific and practical recommendations for public policy, as well as making personal career strategies for the future generation of personnel. The study of the threats of long-term technological unemployment in agriculture as a result of robotization is an urgent problem. We can also highlight the lack of awareness of farmers about the capabilities of robots. This may be associated with training in specialized educational institutions according to outdated programs. It is necessary to modernize the training system at higher agrarian, secondary special and professional educational institutions with an increase of active teaching methods, forming farmers' competencies in working with robotics.

Obstacles for further use of robotics in agriculture, including feed pushers, are poor development or lack of infrastructure in rural areas, as well as the possibility of workers resisting the introduction

of robots. The lack of free cash assets at farmers reduces significantly the possibility of technical modernization of the industry.

Thus, robotization of feeding cattle at a livestock farm should be a priority, as there are objective causes for the use of this equipment and significant advantages of its use in comparison to traditional technologies, which are manifested at the level of economic entities, industry and the state as a whole.

4. CONCLUSION

The use of feed pushers has significant advantages, including an increase in productivity as a result of stimulation of feed intake, a decrease in feed loss at feeding by an average of 50-75%, an increase in the duration of cow activities, and ensuring regular feed intake.

The economic efficiency of using a feed pusher robot, the main effects include the increase in animal productivity 172.4 thousand rubles/year, reduction in feed losses - 923.0 thousand rubles/year, wage savings 340.2 thousand rubles/year. The total economic effect is 1,435.6 thousand rubles per year. The calculation of the economic efficiency of using the robot can be made as to the ratio of the total economic effect and the cost of purchasing and installing the robot, considering operating costs. The estimated return on investment is 87.8%, while the payback period is 407 days.

Thus, the use of a feed pusher robot has many undeniable advantages. It is expected that in the future it is possible to increase the use of these robots, as there is an increase in personnel risks due to a decrease in the rural population and an increasing shortage of labour at rural areas.

5. AVAILABILITY OF DATA AND MATERIAL

Information can be made available by contacting the corresponding author.

6. ACKNOWLEDGMENT

The reported study was funded by RFBR, project number 20-010-00636 A

7. REFERENCES

- Bisaglia C., Belle Z., Van den Berg G., & Pompe J. (2012) Automatic vs. Conventional Feeding Systems in Robotic Milking Dairy Farms: a Survey in the Netherlands. Proc. International Conference of Agricultural Engineering CIGR AgEng. Valencia, 100-104.
- Grothmann A., Moser L., Nydegger F., Steiner A., & Zähler M. (2014). Influence of Different Feeding Frequencies on the Rumination and Lying Behaviour of Dairy Cows. Proceedings International Conference of Agricultural Engineering. Zurich, 1-6.
- Grothmann A., Nydegger F., Häußermann A., & Hartung E. (2010) Automatic Feeding System (AFS) – Potential for Optimisation in Dairy Farming. Landtechnik, 2(65), 129-131.
- Katkov A. A., Kalimullin A. M., Sedykh T. A., Kozlovtssev A. P., Zatin I. M., Kuramshin M. R. (2019). The use of robotic technology in the conditions of the feeding complex. Bulletin of the Orenburg State Agrarian University, 3(77). 157-160.
- Kupreenko A.I., Isaev H.M. (2018). Mikhaylichenko S.M. Operation of an automatic feed car on a dairy farm. // Rural machine operator, 6, 32-33, 40.
- Kupreenko A.I., Isayev H.M., Polyanskaya A.I. (2014). On determining the operational performance of fodder cars // Bulletin of the Bryansk State Agricultural Academy, 1, 3-6.
- Latvietis Ya.Ya., Priekulis Yu.K., Salins A.D. (2013). Problems of providing cattle with concentrated feed during the introduction of loose housing and robotic milking. Actual problems of the intensive development of animal husbandry, 16, Part 1, Gorki, 184-196.
- Morozov N.M., Rasskazov A.N. (2019). The main factors of increasing the efficiency of livestock production in Russia. Economics of agricultural and processing enterprises. 6, 12-15.

Morozova N.I., N.G. Byshova, R.Z. Sadikov, O.V. Zharikova. (2017). The technology of milk production in the conditions of a robotic dairy complex at OOO Vakinsky Agro. Bulletin of the Ryazan State Agrotechnological University named after P.A. Kostycheva. 1(33), 39–43.

Pezzuolo A., Chiumenti A., Sartori L., & Da Borso F. (2016). Automatic Feeding Systems: Evaluation of Energy Consumption and Labour Requirement in North-East Italy Dairy Farm. Engineering for Rural Development. 15, 882- 887.

Voronin B.A., Mitin A.N., Pichugin O.A. (2019). Management of digitalization processes in Russian agriculture. Agrarian Bulletin of the Urals, 4(183), 86-95.



Professor Dr. V.I. Nabokov is Professor. He holds a Doctor of Economics. His research interests are Economics and Management of Organizations, Industries Complexes; Consumer Market; Innovation Activity; Agricultural Problems.



L.A. Novopashin is an Associate Professor. He is a Candidate of Technical Sciences. His scientific interests include Problems of Starting Up transport and Technological machines, Processes of Digitalization of Agriculture, Alternative Types of Energy.



L.V. Denyozhko is an Associate Professor. She is a Candidate of technical sciences. Her scientific interests are Working Processes in Internal Combustion Engines, the use of Digital Technologies in the study of Processes in Thermoelectric Thermometers, research of Alternative Types of Energy.



A. A. Sadov is a postgraduate student. His research interests are Renewable Alternative Types of Energy, Processes of Digitalization of Agriculture, Development of Robotic Complexes for Agricultural Needs.



Professor Dr. N. V. Ziablitckaia is Professor. She holds a Doctor of Economics. Her scientific interests are Business planning, competitive Advantages of the organization, Lean Manufacturing, Development of Petrochemical Clusters, Petrochemical Industry.



Volkova S.A. is a Postgraduate student. Her research interests are Digitalization of Agriculture, Robotization of Agriculture.



I.V. Speshilova is a Post-graduate student. Her research interests are Innovations, Investments, Agrotechservice, Dairy Cattle Breeding, Import Substitution, Three-level Technical Service System, Normative Indicators, Operating Parameters.

Note: The original version of this article has been reviewed, accepted, and presented at the International Scientific and Practical Conference “From Inertia to Development: Scientific and Innovative Support for Agriculture” (IDSISA2020) at the Ural State Agrarian University, Ural, Russia, during 19-20 February 2020.