



Ultra-Wideband based on Automated Guided Vehicle for Localization

Hameedah Sahib Hasan^{1,2}, Mohamad Shukri Zainal Abidin^{1*},
Mohd Saiful Azimi Mahmud¹, Mohd Farid Muhamad Said³

¹ Control and Mechatronics Engineering Department, School of Electrical Engineering, Faculty of Engineering, Universiti Teknologi Malaysia (UTM), Johor, 81310, MALAYSIA.

² Faculty of Engineering, Al-Furat Al-Awsat Technical University, Ministry of Higher Education and Scientific Research, IRAQ.

³ School of Mechanical Engineering, Faculty of Engineering, Universiti Teknologi Malaysia, Johor, MALAYSIA.

*Corresponding Author (shukri @ utm.my)

Paper ID: 12A2C

Volume 12 Issue 2

Received 21 August 2020
Received in revised form 19
October 2020
Accepted 02 November
2020
Available online 24
November 2020

Keywords:

AGV; Localization;
UWB; Target position;
Wireless sensor
network; Kinematic
control system; Labview.

Abstract

Automated Guided Vehicles (AGV) play vital roles in the automation of various processes particularly in the manufacturing industry for distribution of goods, scheduling of machine processes and coordination, and general material flow with high accuracy and precision. In this paper, the localization system using AGV provides information about the dynamic system state, allowing the AGV to predict its position and orientation is designed. At the same time, an Ultra-wideband (UWB) one technology related to wireless sensor network gives necessary information to compensate for the position in terms of (x, y) . One of the major challenges is to maintain accurate data for a long time. The localization system consists of four electrical devices with a UWB sensor which is used to get the accurate target position. Two different device locations are used to measure the target position. The obtained results clearly show the accurate localization for different UWB measurements and their quality. Also, the control system for AGV is developed by using a kinematic control system via Labview.

Disciplinary: Control and Mechatronics Engineering, Navigation Engineering.

©2021 INT TRANS J ENG MANAG SCI TECH.

Cite This Article:

Hasan, H. S., Abidin, M. S. Z., Mahmud, M. S. A., Said, M. F. M. (2021). Ultra-Wideband based on Automated Guided Vehicle for Localization. *International Transaction Journal of Engineering, Management, & Applied Sciences & Technologies*, 12(2), 12A2C, 1-8. <http://TUENGR.COM/V12/12A2C.pdf> DOI: 10.14456/ITJEMAST.2021.24

1 Introduction

Automated guided vehicles (AGV) are vehicles furnished with programmed routing system utilising optical or electromagnetic based systems to achieve desired guidance [1]. They are tasked

with the movement of certain goods or completion of services from a set position to a designated end position [2]. AGV are localized by mainly two types of positioning systems, Local Position System (LPS) and Global Position System (GPS). LPS provides one of the best indoor localization solutions dealing with the estimation of object's or person's positions. Several technologies are utilized to achieving position acquisition by LPS, and these include Bluetooth, Wi-Fi, Infrared Radiation (IR), Radio Frequency Identification (RFID), Ultrasonic, and Ultra-wideband (UWB) [3]. UWB is a wireless technology, mainly used for short-range communications. This paper aims to propose a new method by using LPS through UWB technology for AGV. This paper will be useful for navigation systems aseptically on ranging and positioning.

2 Localization System

Position system is used to get position either on surface area or inside a building. For surface area, GPS is used successively but inside the building, the signal is destroyed therefore it needs to add the system to detected signals inside the building such as LPS. LPS has used several technologies such as IR, Wi-Fi, RFID, Ultrasonic, Bluetooth, UWB [4]. For IR, it has proven low cost and highly precise but the limitation by coverage area, it covers only one room because the signal can't penetrate the wall. IR technology involves a high cost of maintenance with associated expensive hardware [5, 6]. The Wi-Fi is broadly used for LPS without the need for Line of Sight (LOS) while offering high accuracy in position acquisition. RFID offers diverse applications in monitoring and maintenance of processes and products, logistical tracking of products and services, general safety information, and payment processes, etc although, its accuracy dependent on maximal reading ranges as well as the density of tag deployment. In ultrasonic, user locations are estimated using the sound frequency by processing the time taking to transmit an ultrasonic signal between the transmitter and receiver. Bluetooth has the advantages of low power consumption and high security [7, 8]. Finally, It is also very effective as no complex infrastructure is required and tag transceivers are of small sizes. UWB is a wireless technology mostly applicable for short-range communications. Based on radio signals, the positionings are calculated using ultrashort pulse [9]. It gives good precision, higher accuracy with a coverage area of 15-25 m²-D area (for more information see [4]). However, it is costly to deploy with a shorter range of coverage areas.

Table 1: Comparison of LPS technologies.

LPS Technology	Accuracy (m)	Coverage Area (m)	Research by
IR	0.57-2.3	1-5	Brena [11]
UWB	0.2	50-100	Mannay [12]
Wi-Fi	1-5	Building level	Basri [5]
Camera	0.0001	1-10	Mannay [12]
RFID	1-100	0.1-100	Mannay [12]
Ultrasound	0.03-1, 0.3-1	2-10, Building level	Basri [5], William. [13]
Vision	0.01	1-10	Mainetti [6]

Many techniques are employed to evaluate received signals namely, Angle of Arrival (AoA), Time of Arrival (ToA), Time Different of Arrivals (TDOA), Received Signal Strength Indicator (RSSI)

[10]. Table 1 shows a comparison between LPS technologies and selected performance such as accuracy and coverage area depending on the technology. The best coverages are by used Wi-Fi and UWB technologies, while the best accuracy by used IR, UWB.

3 Automated Guided Vehicle (AGV)

The application of AGV in industries is growing rapidly as its importance continues to increase. They are employed in the manufacturing industry as a driverless material handling system (MHS). Other applications are extensively being developed for different areas such as container terminals, industrial warehouses, and transportation services. All materials involved in various manufacturing processes are transported using the Flexible Manufacturing System (FMS). They are equally being deployed for other indoor and outdoor services especially for transportation systems between airports and companies [12]. They are less cumbersome, more flexible, and provides easier solutions with respect to the storage systems [13].

Figure 1 shows the AGV presented in this paper. It has a Single-Board RIO controller sbRIO-9632. It is comprised of a servo motor which has two DC motors drives and is connected to the digital I/O, sensors, and a Parallax PING. The ultrasonic sensor is utilized in avoiding the obstacles in tracking the paths. Tag and router are both attached to achieve suitable position acquisition. Furthermore, the radius of the AGV wheel on right and left is 0.03 m and the distance between the two axis wheels is 0.32 m.

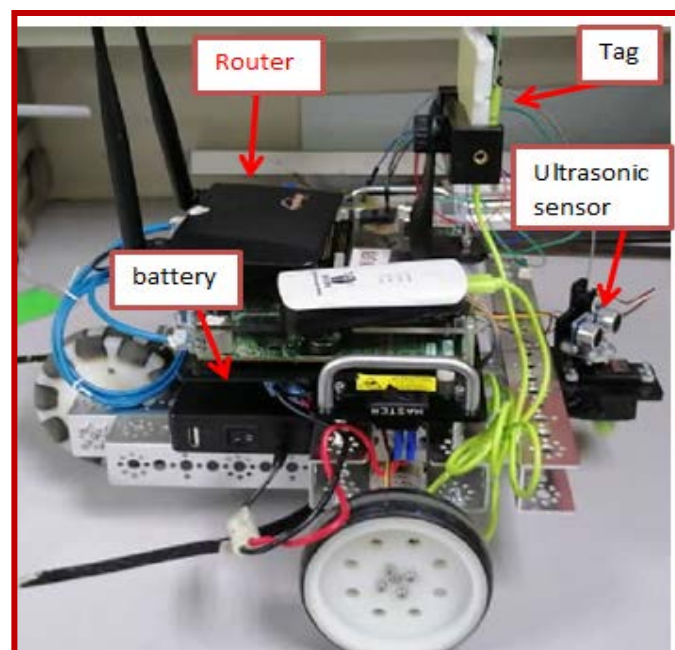

Figure 1: AGV in the experiment with hardware.

4 Ultra-Wideband (UWB) Technology

UWB is a wireless technology that comes with numerous advantages and these include low power spectral density, low transmission power, and high data rate transmission. UWB transmissions take place in the order of nanosecond or even sub-nanosecond pulse signal. It has a very high time resolution, thus, with high information ranging accuracy which could rise to reach

centimeter order. The bandwidth of UWB is high (up to GHz) with a variety of low-frequency components. They can be propagated through the glass, wood, jungle, and other obstacles. UWB has low power consumption and powerful anti-multipath ability [14, 15]. Also, UWB technology is used for ultra-short pulses, wireless communication, or positioning measurement. These advantages promote its attractiveness in LPS applications such as wireless communication and tracking systems [16]. Additionally, UWB occupies a very large bandwidth (more than 1.5 GHz) as they are designed to operate in microwave frequency. Nevertheless, the large bandwidth is responsible for inevitable interference consequently necessitating a strict low power consumption limit. This introduces traditional conservatives on UWB making it impractical for many location-based applications [15, 17].

Table 2: The specification of UWB technology.

Size	Dimension :29mm x 52.7mm
Power consumption	Universal PCB, can be flashed to operate as an anchor or as a tag.
DWM1000 Transceiver	UWB Decawave Localization Transceiver (DWM1000).

The UWB chip used in this paper is the DWM1000 module, produced by Decawave company. Figure 2 shows the DWM1000 modules that were used in the experiment for localization. Its works depend on RF signal and it has accurate Time of Arrival (TOA) measurements. Also, this model uses one switch to connect either the transmitter (TX) or the receiver (RX) with the antenna portion.

The RX section has a front-end RF for the amplification of received signal in a low-noise amplifier which is directly converted into baseband. The RX is optimized to achieve the desired linearity, wide bandwidth, and noise reduction. Each of these is supported by IEEE802.15.4-2011 [18].

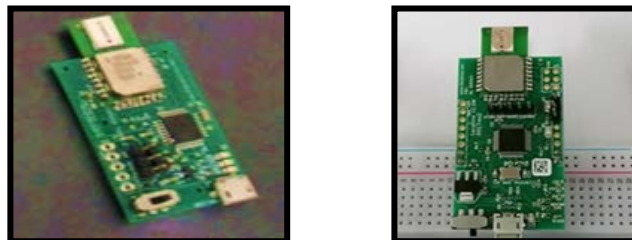
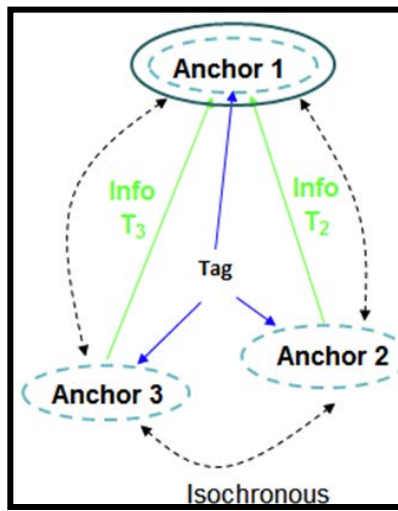

Figure 2: DWM1000 Modules used in the experiment.

5 Time Different of Arrival (TDOA) Technique

ToA requires precise knowledge of the synchronized and sending times between the TX and RX [19], [18] while Time Difference of Arrival (TDoA) deals with relative time for all receiver parts at the same time and does not use the absolute time for nodes. So, the measurement of the synchronized time for the sending signal of the transmitter is not required for position acquisition [19]. However, the RX time is required for synchronization at various parts of the measurements. To get TDoA measurement to any location, the receivers must be paired and then, the TDoA is estimated. Figure 3 shows the used TDoA for the calculation of the different distances between the source and two RX points. Equation (1, 2) is used to calculate the difference [20]:



(a) LPS equipments

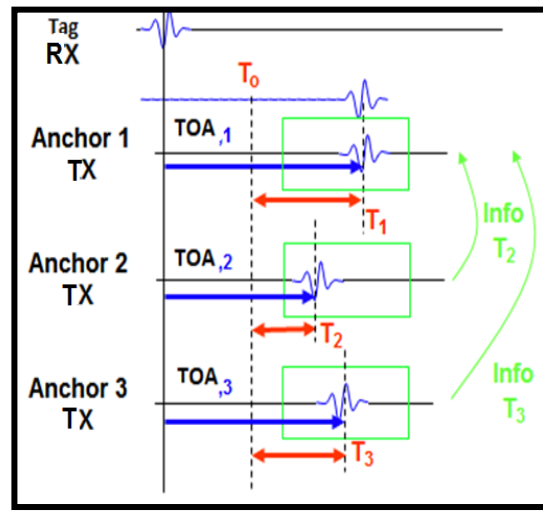

(b) TOA transmit signal (TX) receive signal (RX).

Figure 3: Transmit Signal.

$$T_{21} = T_1 - T_2 \rightarrow d_{21} = T_{21} \cdot V \quad (1),$$

$$T_{23} = T_3 - T_2 \rightarrow d_{23} = T_{23} \cdot V \quad (2).$$

Table 3. Comparison between LPS techniques.

Method	LPS Accuracy	LOS/NLOS	Multipath Affected	Cost	Note
Time Different of Arrival (TDOA)	High	LOS Only	Yes	High	<ul style="list-style-type: none"> Requires precise time synchronization between receivers. Receiver locations must be known.
The Angle of Arrival (AOA)	Medium	LOS Only	Yes	High	<ul style="list-style-type: none"> Accuracy based on antenna's angular characteristics. Receiver locations must be known.
Time of Arrival TOA	High	LOS Only	Yes	High	<ul style="list-style-type: none"> Requires precise time synchronization between the receiver part and transmitter part. Receiver locations must be known.
RSSI	Low	NLOS Only	Yes	Low	<ul style="list-style-type: none"> RSS usually gives inaccurate values and it leads to errors in localization. No additional hardware.

6 System Design

The system designed in four poses, three anchors with known positions, and one tag represented user position. The tag transmits signals to the three anchors via UWB. Two different positions for anchors had carried out which is successful to get the accurate target position. The user position is obtained depending on the triangulation method. The obtained results clearly show the accurate localization for different UWB measurements and their quality.

7 Result

A practical environment is used to implement the kinematic control of the AGV motion. The environment is of different interconnected nodes to form a graphical structure. From the source to destination points, the AGV determines and follows the shortest path successfully. The AGV path matches the optimal path as obtained from simulation results.



Figure 4: AGV in position (2,0.5)

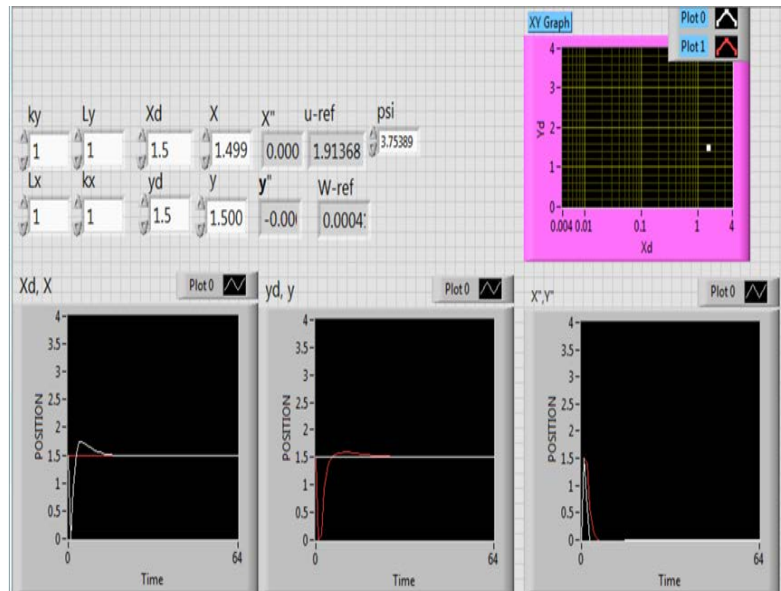

Figure 5: Kinematic control.

In Figure 4, the AGV motion is stopped in position (2, 0.5), though LPS experiment using a wireless communication network. While Figure 5 shows the front panel of kinematic control. It contains different parameters such as k_x, k_y, L_x, L_y . For those parameters, different values are chosen according to AGV motion. Here all the parameters are selected =1, the AGV motion starts from point (3,0) till the destination point (1.5, 1.5).

In Figure 6 the AGV motion started from(0.4,0.1), then moved toward the destination point at (2.5,2.5). While Figure 7 shows the AGV motion from the start point (0.4,0.3) till reaches the destination point (3, 2.5). In the experiment, AGV motion is close to real motion, this means the stability of AGV is high.

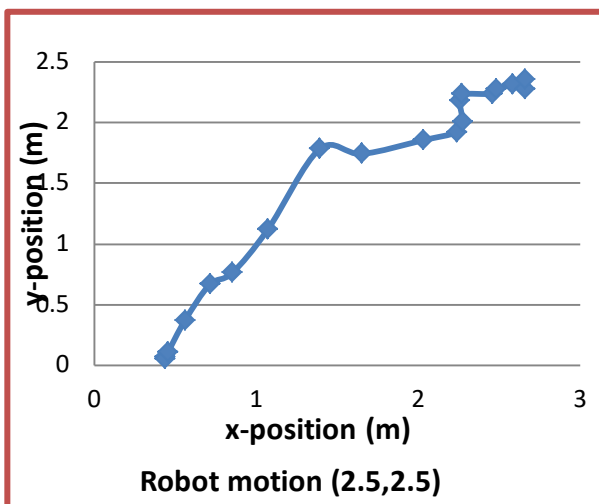

Figure 6: AGV motion for point (2.5, 2.5).

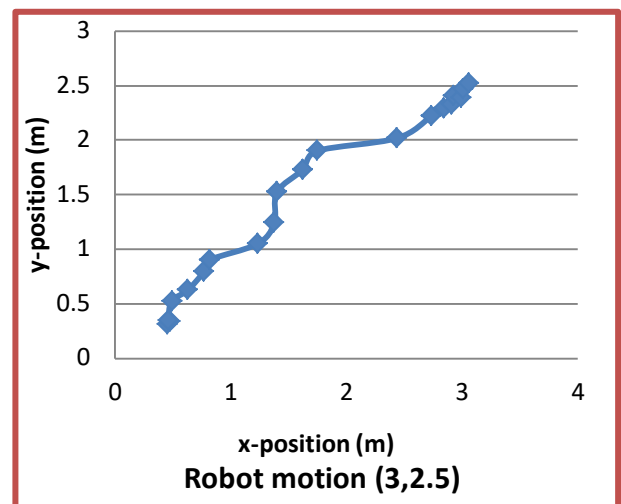

Figure 7: AGV motion for point (3, 2.5)

8 Conclusion

In this paper, the localization system using AGV provides information about the dynamic system state, allowing to predict its position and orientation is presented. At the same time, an Ultra-Wide Band (UWB) one technology related to wireless sensor network gives necessary

information to compensate for the position in term of (x,y) is discussed. Furthermore, a localization experiment had carried out to perform the target position. The obtained results clearly show the accurate localization for different UWB measurements and their quality. Furthermore, the controller for the system is built by using the Labview environment with a kinematic control system. We are sure this paper will be catalyzed by the researcher for further investigates of localization especially with UWB for ranging positioning and AGV motion.

9 Availability of Data and Material

Information can be made available by contacting the corresponding author.

10 References

- [1] Hasan, H. S., Abidin, M. S. Z., Mahmud, M. S. A., & Mohd, F. M. S. (2019). Automated Guided Vehicle Routing: Static, Dynamic, and Free range. *International Journal of Engineering and Advanced Technologies*, 8(5):1-7.
- [2] Qing G, Zheng Z, Yue X. (2017). Path-planning of Automated Guided Vehicle based on Improved Dijkstra Algorithm. *29th Chinese Control And Decision Conference (CCDC)*;7138-43.
- [3] Timea, B., & Zoltan, B. (2011). Indoor localization by WiFi. *IEEE 7th International Conference on Intelligent Computer Communication and Processing (ICCP)*, 449-452.
- [4] Hameedah Sahib Hasan, Mohamed Hussein, Shaharil, M. S., & Mohd, A. M. D. (2018). An Overview of Local Positioning System: Technologies, Techniques and Applications. *International Journal of Engineering & Technologies*, 7(3): 1-5.
- [5] Basri C, El Khadimi A. (2017). Survey on indoor localization system and recent advances of WIFI fingerprinting technique. *International Conference on Multimedia Computing and Systems*, 253-260.
- [6] Mainetti, L., Patrono, L., & Sergi, I. (2014). A survey of indoor positioning systems. *2014 22nd International Conference on Software, Telecommunications and Computer Networks (SoftCOM)*, 111-120.
- [7] Farid, Z., Nordin, R., & Ismail, M. (2013). Recent advances in wireless indoor localization techniques and systems. *Journal of Computer Networks and Communications*, 1-12.
- [8] Jun.-Ho, H., & Kyungryong, S. (2017). An indoor location-based control system using Bluetooth beacons for IoT systems. *Sensors MDPI*, 17(12), 1-22.
- [9] Angrisani, L., Arpaia, P., & Gatti, D. (2017). Analysis of localization technologies for indoor environment. *2017 IEEE International Workshop on Measurement and Networking (M&N), Naples*, 1-5.
- [10] Miši, J. (2015). An Overview of Wireless Indoor Positioning Systems. *Infotech-Jahorina*, 14, 301-306.
- [11] Brena, R. F., García-Vázquez, J. P., Galván-Tejada, C.E., Muñoz-Rodríguez, D., Vargas-Rosales, C., & Fangmeyer, J. (2017). Evolution of Indoor Positioning Technologies. *Journal of Sensor*, 1-21.
- [12] Mannay, K., Benhadjoussef, N., Machhout, M., & Ureña, J. (2016). Location and Positioning Systems: Performance and Comparison. *Proceedings of 2016 4th International Conference on Control Engineering & Information Technology, Tunisia, Hammamet*, 1-6.
- [13] William, S., Salil, B., & Adam, H. (2012). System-level noise of an ultra-wideband tracking system. *In IEEE The 11th International Conference on Information Science, Signal Processing and Their Applications (ISSPA), Montreal, QC*, 634-639.

- [14] Van der Heijden, M. C., Van Harten, A., Ebben, M. J. R., Saanen, Y. A., Valentin, E. C., & Verbraeck, A. (2002). Using simulation to design an automated underground system for transporting freight around Schiphol Airport. *Interfaces*, 32(4), 1-19.
- [15] Secchi, C., Olmi, R., Rocchi, F., & Fantuzzi, C. (2015). A dynamic routing strategy for the traffic control of AGVs in automatic warehouses. *Proceedings. IEEE International Conference on Robotics and Automation*, 3292-3297.
- [16] Sachs, D. I. J. (2012). Handbook of Ultra-Wideband Short-Range Sensing. *Wiley-VCH Verlag GmbH & Co. KGaA, Germany*, 1-30.
- [17] Zhao, L., Psota, E. T., & Perez, L. C. (2014). A comparison between UWB and TDOA systems for smart space localization. *IEEE International Conference on Electro Information Technology*, 179-183.
- [18] Dokania, R. K., Wang X. Y., Tallur, S. G., & Apsel, A. B. (2011). A low power impulse radio design for body-area-networks. *IEEE Transactions on Circuits and Systems I: Regular Papers*, 58(7), 1458-1469.
- [19] Oguntala, G., Abd-alhameed, R., Jones, S., Noras, J., Patwary, M., & Rodriguez, J. (2018). Indoor location identification technologies for real-time IoT-based applications : An inclusive survey. *Computer Science Review*, 30, 55-79.
- [20] Ravindra, S., & Jagadeesha, S. N. (2013). Time of Arrival Based Localization in Wireless Sensor Networks: A Linear Approach. *Signal & Image Processing : An International Journal (SIPIJ)*, 4(4), 13-30.
- [21] Gustafsson, F., & Gunnarsson, F. (2003). Positioning using time-difference of arrival measurements. *2003 IEEE International Conference on Acoustics, Speech, and Signal Processing, (ICASSP '03)*, 553-556.



Hameedah Sahib Hasan is a doctoral student at the School of Mechanical, Faculty of Engineering, Universiti Teknologi, Malaysia. She received her B.Eng. in Mechanical Department from Technology University Bagdad, Iraq; a Master of Engineering in Mechanical Engineering, Automation and Robotics from University College of Engineering, Osmania University, Hyderabad, India, 2013. She is a Lecturer, at Al-Furat Al-Awsat Technical University, Iraq.



Dr. Mohamad Shukri Zainal Abidin is an Associate Professor at the Control and Mechatronics Department, Faculty of Electrical Engineering, Universiti Teknologi Malaysia (UTM). He received his B. Eng. in Electrical Engineering from Universiti Teknologi Malaysia (UTM), an MSc in Electrical Engineering from Universiti Teknologi Malaysia (UTM) and a PhD in Agriculture Engineering from Tokyo University of Technology, Japan in 2014. His research interests involve Adaptive Control Strategies in Fibrous Capillary Irrigation System and Agricultural Robotics.



Dr. Mohd Saiful Azimi Mahmud is a Senior Lecturer at Control and Mechatronics Department, Faculty of Electrical Engineering, Universiti Teknologi Malaysia (UTM). He received his B. Eng. in Electrical Engineering, majored in Control and Mechatronics from Universiti Teknologi Malaysia (UTM), and a Ph.D. in Electrical Engineering from Universiti Teknologi Malaysia (UTM). His research interest is related to the field of Multi-Objective Optimization, Robotics And Control System And Image Processing Applications.



Dr. Mohd Farid Muhamad Said is an Associate Professor at the School of Mechanical Engineering, Faculty of Engineering, Universiti Teknologi Malaysia (UTM). He received a Bachelor's and Master's degree in Mechanical Engineering from UTM. He got a PhD degree in Mechanical Engineering from the University of Leicester, United Kingdom. In 2006, Currently, he and his research interests include Internal Combustion Engine, Alternative Fuel and Spray Droplet Characterization, and Underwater Vehicle.