



Redesigning the Base Eye of a Telescopic Hydraulic Cylinder with Topology Optimization Method

Zejnlabedin Aziri^{1*}, Elizabeta Hristovska¹

¹ Faculty of Technical Sciences, University St. Kliment Ohridski - Bitola, RNMacedonia.

*Corresponding Author (Tel: +38978229990, Email: zejnelabedin.id@gmail.com).

Paper ID: 13A10

Volume 13 Issue 1

Received 01 August 2021
Received in revised form 02
November 2021
Accepted 11 November
2021
Available online 19
November 2021

Keywords:

Topology optimization;
Mass reduction;
Autodesk Inventor;
Finite Element Analysis;
Shape generator; Digital
sketching; CAD; Von
Mises law.

Abstract

Recently, various optimization methods are being used in the design process in order to find the optimized form of products under different given conditions. The use of topology optimization has enabled engineer designers and industrialists to achieve lighter-weight products cost-effectively and at less time-consuming processes without losing their intended design purposes. In this study, topology optimization using Autodesk Inventor Software is applied to a component of a front-end telescopic hydraulic cylinder to reduce the mass by at least 30% of the original weight while satisfying the pressure constraints of 18 MPa. Furthermore, sketches are drawn based on the forms derived from topology optimization and the final design is generated into CAD. Finally, finite element analysis is done upon the final model in order to conduct the durability analysis. The results show that the model of the component obtained with topology analysis has been reduced by 30.77% of the original weight while ensuring normal operation under the given constraints.

Disciplinary: Industrial Management, Product Design.

©2022 INT TRANS J ENG MANAG SCI TECH.

Cite This Article:

Aziri, Z., and Hristovska, E. (2022). Redesigning the Base Eye of a Telescopic Hydraulic Cylinder with Topology Optimization Method. *International Transaction Journal of Engineering, Management, & Applied Sciences & Technologies*, 13(1), 13A10, 1-8. <http://TUENGR.COM/V13/13A10.pdf> DOI: 10.14456/ITJEMAST.2022.15

1 Introduction

The increase in competitiveness in the global market creates the need for increased innovation in the product design development process. This forces the designers, engineers and industrialists to find ways to manufacture high-quality products with minimal costs and in a less time-consuming process. In the conventional design approach, the designs are upgraded based on the evaluation of the design feedback and the perception of the design engineers (Ragai et. al. 2011). As reaching a compromise between the design objectives and constraints is difficult, there

are no clear ways how to redesign a product. As a result, the conventional design approach may not always be the right method to achieve the best-needed design solution (Stander et. al. 2004). With the implementation of the techniques of optimization in the process of design, engineers have been able to produce powerful designs without hard prototyping and testing all possible options physically, which moreover leads to more cost-effective and less time-consuming design processes. (Ragai et. al. 2011). One of the techniques that designers and engineers use for product optimization is the topology optimization method. Topology optimization has been used by engineers to reduce the amount of used material and the stress-energy of products while preserving their mechanical strength (Bendsoe et. al., 2003). This is a numerical method that physically optimizes the material distribution within a defined domain, by satisfying given conditions and minimizing the cost (Rosinhaa et. al. 2015). In this study, topology optimization is used in the redesign process of a front-end telescopic hydraulic cylinder part (base eye), intending to reduce its weight by at least 15% of the original weight while improving its performance and avoiding deformations.

2 Literature Review

The main idea behind the topology optimization is to distribute the material within the designed structure in the best way possible by also meeting the required constraints (Ragai et. al. 2011). In terms of design, a topology method considers a repetitive design process of a products' form until it will reach the preferred optimized goal - such as minimizing mass, balancing the specific stiffness or minimizing maximum amplitude - based on the applied loads and geometric restrictions. (Dassault Systèmes, 2018). In other words, a topology optimization uses a repetitive algorithm in order to get a simpler shape based on the defined limitations, geometric constraints, and manufacturing controls (Dassault Systèmes, 2018).

Topology optimization has been widely used especially as a result of the progress and development of computing power and speed, which has had an outstanding effect on the design process, by replacing the conventional design based on paper and hand calculations with a digital design (Querin et. al. 2017).

With topology optimization, we can get more innovative, cost-effective and less time-consuming designs as it enables us to skip some long processes of traditional design phases. By starting to work on an existing model from which an optimal shape based on the defined design requirements, we can avoid wasting time on the creation of the model and instead focus more on the purification and improvement of the design.

Considering the new trends towards the products getting smaller and smaller, minimizing the mass has become an important task for industrialists and engineering designers. Many industries work on reducing product weight and material usage, which is easily and effortlessly done through topology optimization techniques that aim at reaching an optimized design through the best specific stiffness, minimizing mass and maximum displacement (Dassault Systèmes, 2018).

In other words, with topology optimization, we get lighter and smaller components and less material usage, while functioning properly under the required constraints.

3 Method

The methodology is based on the use of topology optimization and the finite element method. The workflow of the design process is presented in Figure 1. As it can be seen the design process contains four main phases: The first phase starts with generating a CAD model of an old design of the base eye. Next, the topology optimization is applied using the Autodesk Inventor, with the help of the shape generator module. The third phase consists of idea generation through numerous hand sketches and their final design interpretation in CAD. The fourth phase consists of product simulation.

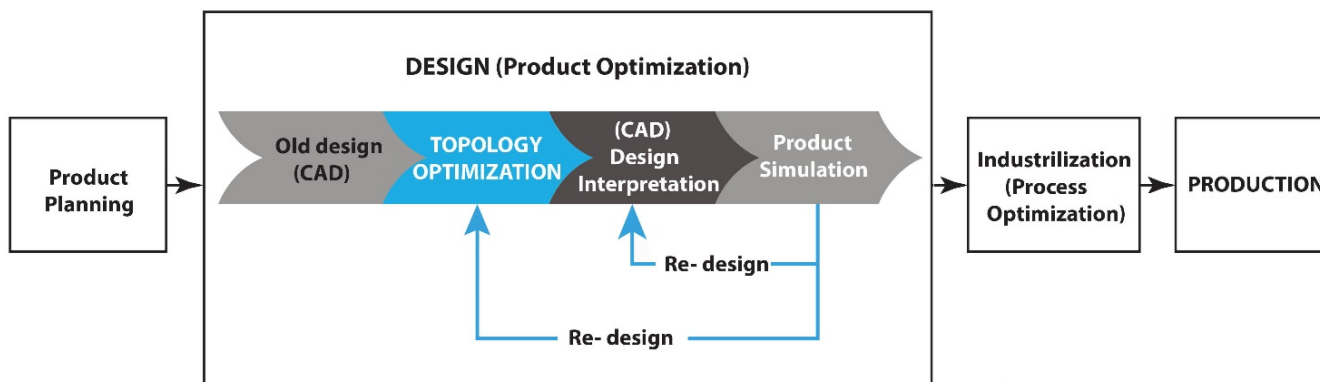

Figure 1: Phases of the design process using topology optimization method.

Finally, FEA is conducted for durability analysis (applying fixtures on the structure, applying loads, meshing, determining strains and deformations). The material used for the old base eye model is AISI 1035 SAE Carbon Steel, and its properties are shown in Table 1.

Table 1: Characteristics of old models material.

Properties	Value
Young modulus	20000MPa
Tensile strength	585MPa
Modulus of elasticity	190-210GPa
Elongation	8-25 %
Fatigue	275MPa
Yield strength	370MPa
Specific heat	434 J/kg K
Density	7850 kg/m3

The properties of the meshing process in the performed topology optimization are represented in Table 2.

Table 2: Mesh characteristics

Number of nodes	348577
Number of elements	235486

3.1 Topology Optimization

The product optimization is done upon an existing model of a front-end telescopic hydraulic cylinder component. Firstly, the old model is generated in CAD (Figure 2) and by using the design system Autodesk Inventor we start with the form optimization. The steps performed in this process are the material selection, application of fixtures on the supporting surfaces and application of 18MPa pressure to this model. To reach the optimal form, we have to set the percentage of weight reduction that we want to achieve for the final model. The required percentage of weight reduction is set in the parameters of the shape generator; in our project, the objectives for the percentage of weight reduction were 15%, 25%, and 35%. The optimized forms derived from the topology optimization are shown in Figure 3. The shape generator derives a proposed design for each detail, visually reflecting where we have material excess in order to cut unnecessary parts while maintaining stiffness and durability (Figure 4).

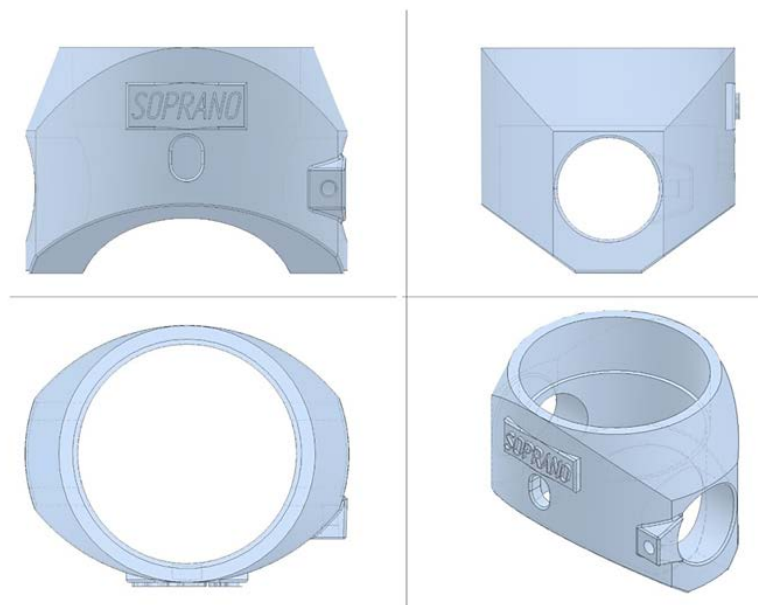

Figure 2: CAD model of the old design.

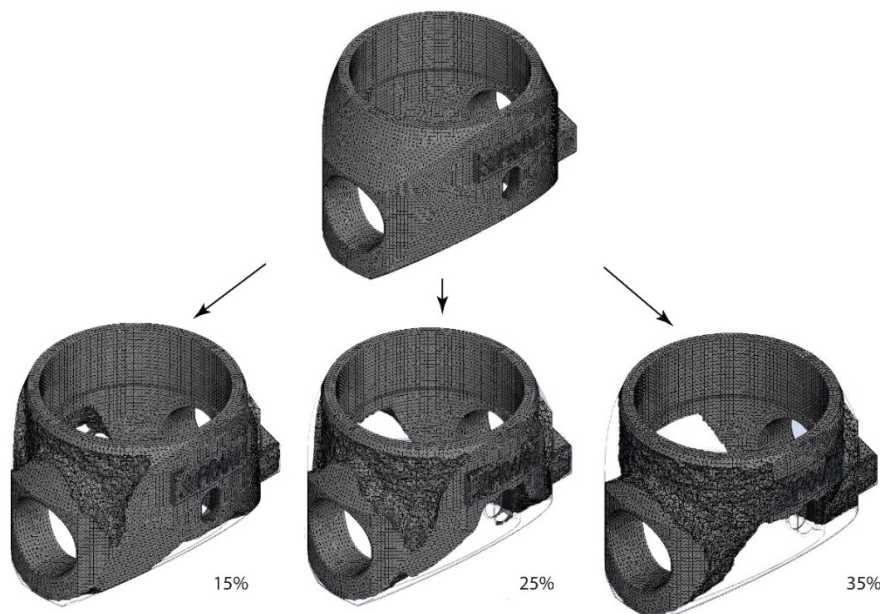

Figure 3: Mass reduction of the existing model with topology optimization tools.

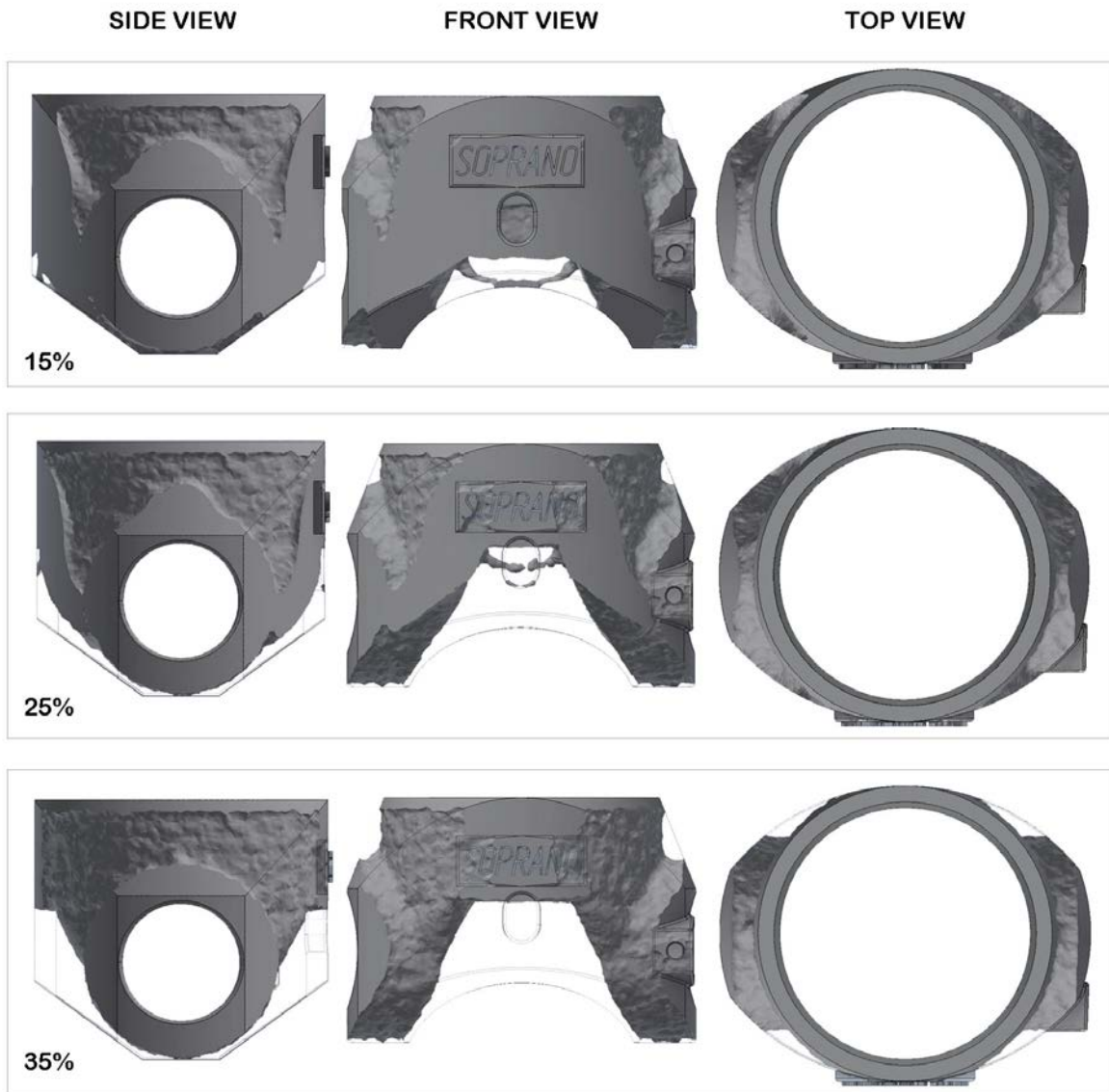

Figure 4: Different views of mass reduction of the original model using topology optimization.

3.2 Idea Generation and Design Interpretation

According to the results of the shape generator, a number of sketches are drawn by hand in order to obtain the final design (Figure 5). The final sketches are derived (Figure 6) from which concept B is chosen by the team. The chosen design is generated in CAD (Figure 7) regarding the shape generator recommendations, in order to recalculate its durability using the FEA approach.

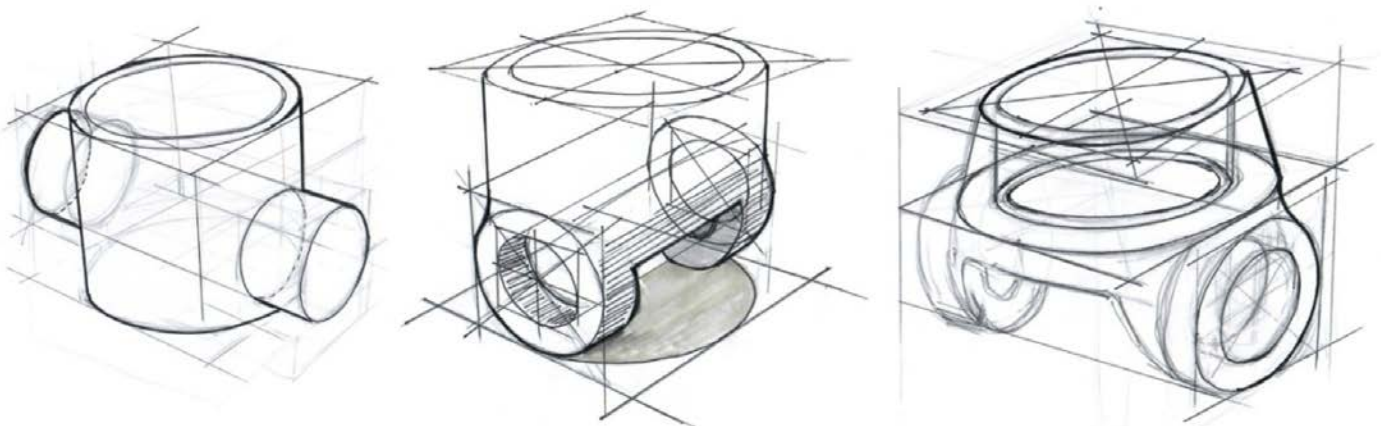

Figure 5: Hand-drawn sketches of the base eye based on the shaper generator recommendations.

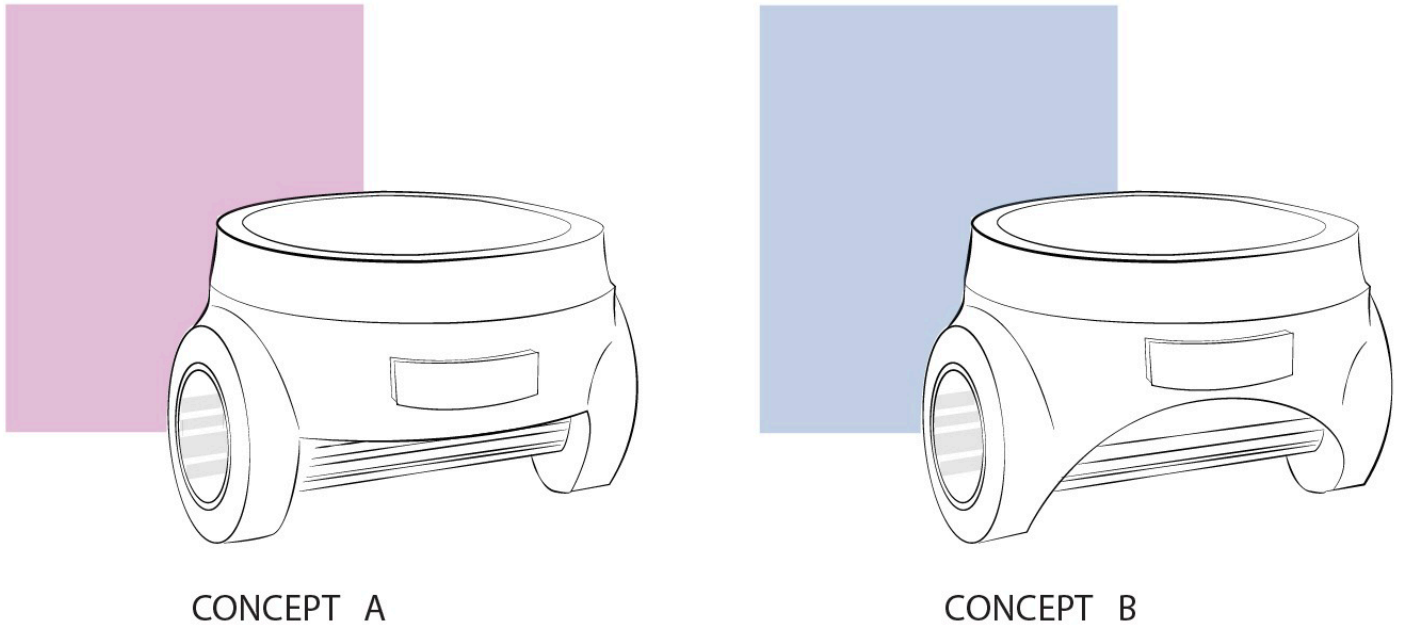

Figure 6: Final sketches for the proposed base eye design.

4 Result and Discussion

To test and evaluate the final design, FEA study is conducted on the model with the help of the Solidworks software program. Firstly, based on the topology optimization recommendations, the final model of the base eye is generated in CAD (Figure 7).

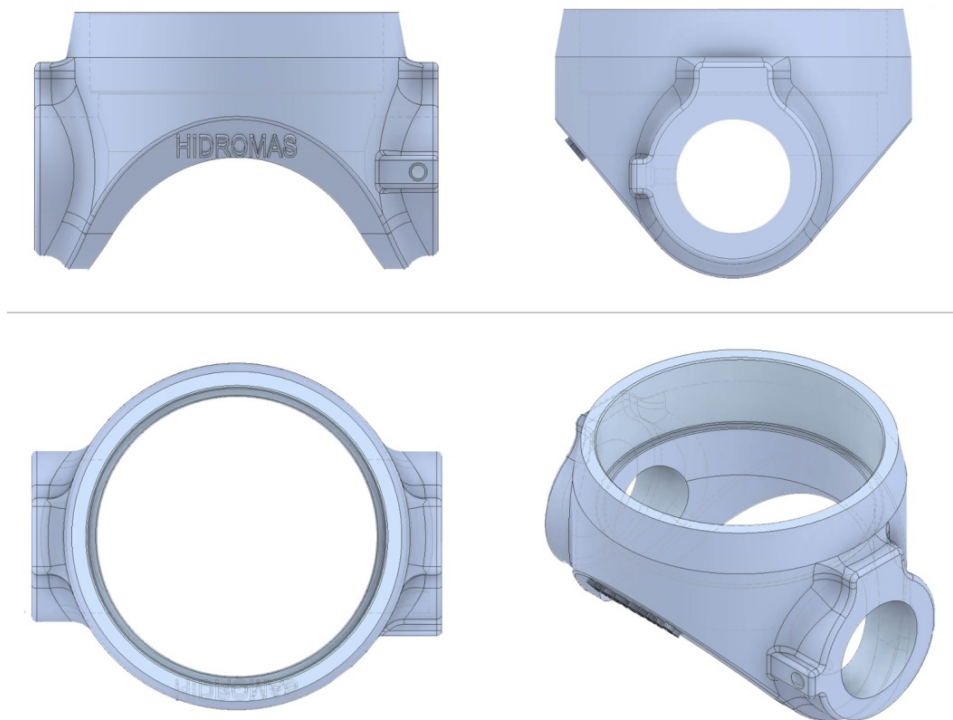

Figure 7: CAD model of the new design

After that, the specifications are analyzed based on the collection of product information in relation to the functional specifications, loading conditions and materials to be used in FEA. FEA is used to predict stress distribution and deformation by simulating a redesigned model. To determine the load, Von Mises law is applied which is the value used to determine if the product material will

be rigid/elastic or "loose". The simulation helps achieve easier, faster, and more cost-effective design cycles that will replace the prototype's time-consuming and expensive testing.

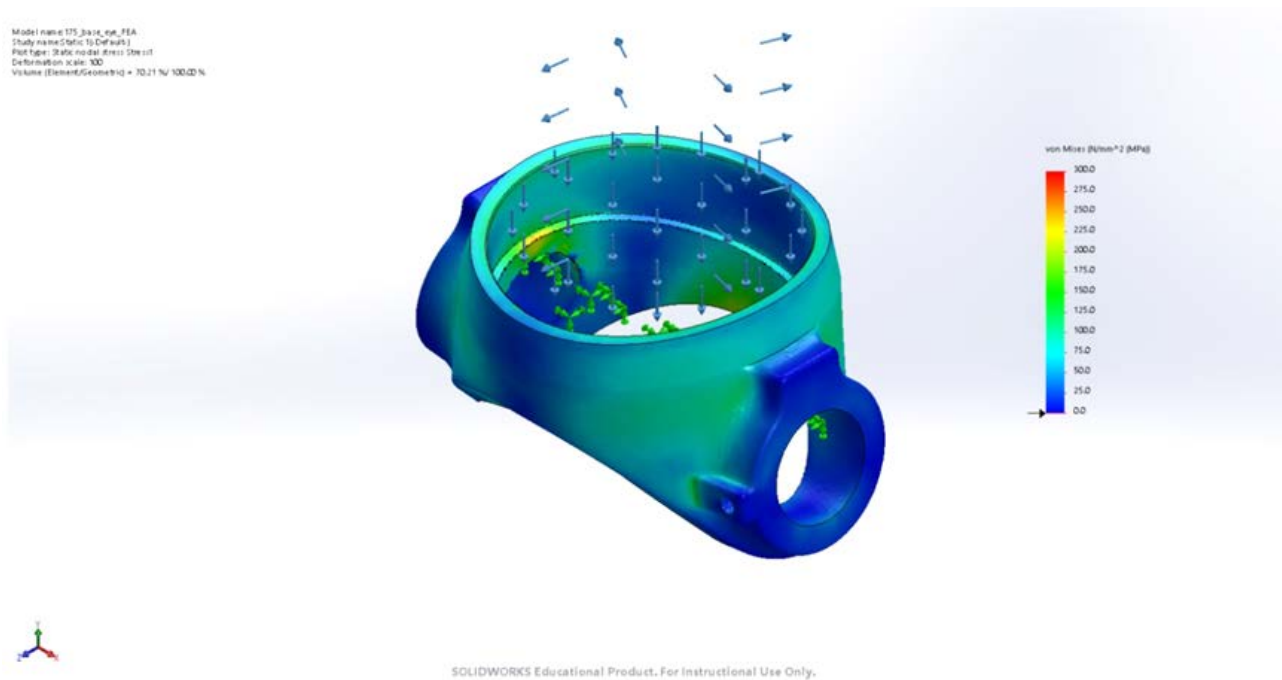

Figure 8: Results of FEA simulation

Figure 8 shows the durability analysis using the FEA module by applying a fixture on the bottom end (Figure 8) and a pressure of 18 MPa on the upper side directed towards -y-direction. As we can see from the results the form derived from topology optimization and the selected material shows great durability with regard to the relevant pressure and good distribution of stress.

5 Conclusion

Designing optimal products with maximum durability is a time-consuming and costly process. The application of topology optimization in the early phases of the design process can lead to a more cost-effective and less time-consuming design process by avoiding the steps of physical prototyping during that process.

This study proposes a redesign methodology for a component of a telescopic hydraulic cylinder used in dump trucks, called the base eye of the cylinder, using CAD / CAE methods and sketching techniques in the redesign process. This redesign was made in order to overcome the problems that arose in the production phase of the hydraulic cylinders and to reduce the costs and the material used to create the base eye of the telescopic hydraulic cylinder. In this study, topology optimization is successfully used in order to obtain an optimal form and lighter product of a front-end telescopic hydraulic cylinder component – the base eye.

Using the optimization method, the metal capacity of the existing model was reduced by 30.77% where the mass of the product was reduced from 13.05 kg to 9.07 kg. Finite element analysis was conducted in the final model, by which the obtained model ensured normal operation under the pressure of 18 MPa, thus satisfying the loading constraints and the functions that it was aimed

to perform. Given these results, topology optimization can be seen as a great method to achieve faster and decent designs at economic costs and at less time-consuming processes.

6 Availability of Data and Material

Data can be made available by contacting the corresponding author.

7 References

- Bendsoe M. P., & Sigmund, O. (2002). *Topology Optimization: Theory, Methods and Applications*. 2nd Ed., Heidelberg: Springer, Berlin, Germany.
- Dassault Systèmes (2018). *Design Through Analysis: Improving Product Design and Automating Manufacturability with Topology Optimization*. [White paper]. 3DEXPERIENCE®Company. <https://www.solidworks.com/sites/default/files/2018-10/DS-18031-Designer-to-Analyst-Topology-Whitepaper.pdf>
- Ragai, I., Tempelman, H., & Kirby, D. (2011). Application of Topology Optimization in Product Design and Manufacturing. *ASME 2011 International Manufacturing Science and Engineering Conference*, 1. DOI: 10.1115/msec2011-50049
- Rosinha, I. P., Gernaey, K. V., Woodley, J. M., & Krühne, U. (2015). Topology optimization for biocatalytic microreactor configurations. *Elsevier B.V.*, 1463–1468.
- Stander, N., Roux, W., Eggleston, T., and Craig, K. (2004). *LS-OPT User's Manual: A design optimization and probabilistic analysis tool for the engineering analyst*. LSTC, Livermore, CA.
- Querin O., Victoria M., Gordo C., Ansola R. & Marti P. (2017). *Topology Design Methods for Structural Optimization*. Academic Press.



M.Sc. Zejnelabedin Aziri is a PHD student at the faculty of Technical Sciences, St. "Kliment Ohridski" - Bitola University, R. North Macedonia. He got a Bachelor's degree at the Department of Industrial Design, Middle East Technical University, in Ankara, Turkey, and a Master's degree at the faculty of Wood Technologies and Furniture Design, Ss. "Cyril and Methodius University" in Skopje, R. North Macedonia. His research areas are CAD/CAE Technologies in Product Design.



Dr. Elizabeta Hristovska is a Full Professor at the Department of Industrial Engineering and Management, Faculty of Technical Sciences, St. "Kliment Ohridski" -Bitola University, R. North Macedonia. She got her Master's and PhD degrees in the Department of Mechanical Engineering at Ss. "Cyril and Methodius" University in Skopje, R. North Macedonia. Her research focuses on the Design of Machine Structures, Machines and Vehicles.