



A Novel Hybrid (Active & Passive) Islanding Detection Method for Distributed Generation System

B Hariprasad^{1*}, P Bharat Kumar¹, P Sujatha¹, G Sreenivasan²

¹Department of Electrical & Electronics Engineering, JNTUA CEA, Anantapuramu. A.P., INDIA.

²Department of Electrical & Electronics Engineering, PVKK Institute of Technology, Anantapuramu, A.P., INDIA.

*Corresponding Author (Email: vanoorhari@gmail.com).

Paper ID: 13A9F

Volume 13 Issue 9

Received 10 February 2022

Received in revised form 10 June 2022

Accepted 17 June 2022

Available online 24 June 2022

Keywords:

Active and passive Model; Bilateral Reactive Power Variation; Voltage Unbalance/Total Harmonic Distortion

Abstract

This research proposes a new hybrid method for detecting islanding in Distributed Generation (DG) units, based on the combination of an active and a passive approach, with the active method being Bilateral Reactive Power Variation (BRPV) and the passive method being Voltage Unbalance/Total Harmonic Distortion (VU/THD). To detect the islanding of the DG system, active and passive models are used. By combining these models, it is possible to minimize each model's limitations while also incorporating its benefits. In particular, the BRPV technique is triggered only if the VU/THD method suspects island status. The performance of islanding detection is much improved as a result of this. First, a decoupled dual synchronous reference frame phase lock loop (PLL) with a better dynamic response is used to extract the positive and negative series components of the point of common coupling (PCC) voltage. To avoid imprecise detections caused by normal voltage fluctuation, a low-pass filter is used. Thus, the detection sensitivity improves. The conventional VU/THD approach thus concurrently tracks VU and current THD, however, it is discovered to be more sensitive to VU disturbances than current THD. Thus, the voltage THD is investigated in the proposed method. When compared to the other techniques, the improved VU/THD has higher efficiency. The BRPV method reduces reactive power by changing the amplitude of output reactive power between the positive and negative valves. As a result, the reactive power perturbation time is reduced, and power quality is improved. The proposed technique's performance is then activated in MATLAB/Simulink, and the results are assessed prior to, during, and the following islanding.

Disciplinary: [Electronical Engineering.](#)

©2022 INT TRANS J ENG MANAG SCI TECH.

Cite This Article:

Hariprasad, B., Kumar, P.B., Sujatha, P., Sreenivasan, G. (2022). A Novel Hybrid (Active & Passive) Islanding Detection Method for Distributed Generation System. *International Transaction Journal of Engineering, Management, & Applied Sciences & Technologies*, 13(9), 13A9F, 1-16. <http://TUENGR.COM/V13/13A9F.pdf>. DOI: 10.14456/ITJEMAST.2022.174

1 Introduction

Nowadays, the operation of distributed generations (DGs) and microgrids are working based on the operating conditions and security systems of the DGs. Many requirements are raised while interfacing the distributed generator to the power grid. The island phenomenon is one of the most important challenges that have been commonly discussed over the years. As per IEEE Standard 1547, an island is an isolated part of the electrical system from the rest of the network, the isolated area has at least one DG [1]. Accidental isolation is an unacceptable operating system that can pose an existential threat to the distributed generator, utility systems, and consumer devices. Also, it threatens the security of utility employees and customers. The causes of the island and its effect are considered in [1], [2] and [3]. The need for DG protection is linked to an important, systematic anti-island secure program. Several island detection approaches were presented over the past years that were categorized into 3 types: contact-based, passive, and active. Switching data between power consumption and the DG unit operate based on communication-based methods, also they are effective, but its disadvantage is the cost of execution.

In [4,5], the more common contact-based techniques utilized for island detection are considered. At PCC, Passive island detection strategies are established for managing system parameters as well as tracking its variations [6]. Low / high voltage secure, low / high frequency secure modes [7,8], voltage phase jump mode [9], frequency protection mode conversion rate [10], ratio active power modification [11], voltage imbalance with total harmonic degradation method are usually utilized passive modes [12]. Passive models are called island detection models that do not create any interruption to the system. The major disadvantage of passive techniques is its huge non-detection zone (NDZ) that fails when it is a smaller electrical mismatch among the DG and load. Moreover, active island detection techniques according to the event of interruption on the terminal of distributed generator, while distributed generator gets disconnected from the power grid it have a consequential difference [13]; consequently, active models remain effectual, despite there being smaller power imbalance among load demand and distributed generator capacity.

The active models are the Slip-Mode frequency Shift technique (SMS) [14], Active Frequency Drift method (AFD) [4], Sandia Frequency Shift method (SFS) [15], and Sandia Voltage Shift method (SVS). Reducing power quality and slower detection compared to passive modes are the disadvantages of active modes [13]. Moreover, active with passive techniques contains advantages as well as disadvantages. These 2 models are combined to take advantage of all the merits, a novel type of island defense strategy named hybrid anti-island methods [15]. Some of the recent literature that has focused on the hybrid island detection method is: The active method is a strong hybrid island detection method due to the compressing of the current injection method, frequency relay, voltage relay, THD is the passive model [15]. In the positive feedback (active) model, the voltage imbalance with the total harmonic decomposition (passive) technique combine as an effective technique for integrated rotation of DG [16]. The frequency conversion rate of a digital

signal processor (DSP), voltage conversion rate, and the correction factor of a distributed synchronous generator determine whether travel conditions are satisfied [17]. In [18], due to connecting the average rate of voltage change with the actual power change, the average rate of a voltage change (passive) is utilized for initiating an actual power change (active) [19, 20].

2 Design Principle of the Hybrid Method

It is necessary to first fully understand its properties to model a hybrid system with satisfactory production. In hybrid mode, when the island position is suspected by the passive method the active mode is only triggered, and finally, the tripping function is performed through the active mode.

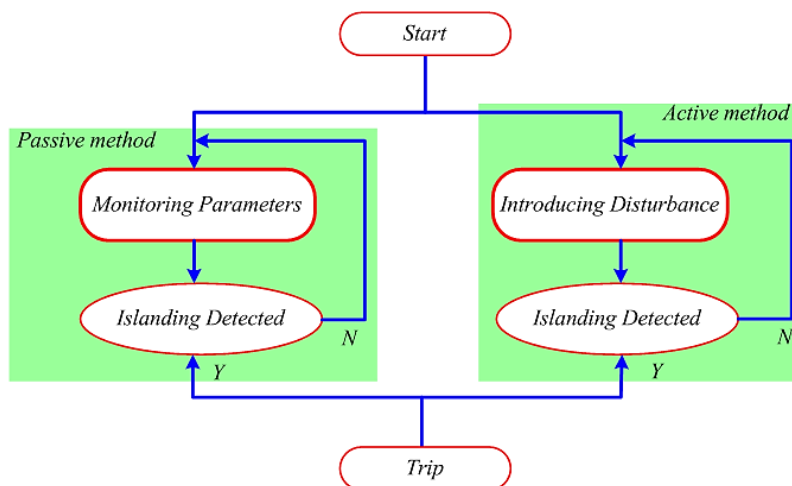

Figure 1: The principle of combining passive and active acts in parallel mode

3 Proposed Hybrid Islanding Detection Method

The parallel RLC's local load and phase are coupled to PCC and utilised to activate the breaker island state event. Because of the bad circumstance for skillful detection of accidental islands, the resonance frequency of the parallel RLC load is adjusted to the local application operating frequency. The isolated situation can be recognized with a quality factor of local load $Q_f \leq 2.5$ and a detection time of less than 2s, depending on the standard process [29]. The following sections discuss the passive, active, and hybrid modes of operation.

3.1 Voltage Unbalance and Total Harmonic Distortion Method

The VU/THD system is known as the most sensitive passive detection approach that can cause troublesome travel in certain situations.

This paper changes the regular VU/THD approach and gets greater performance. First, the components positive with negative series for PCC voltage have been evaluated through double-linked dual synchronization reference PLL; also it has a greater dynamic response [30]. A low-pass filter is utilized to avert misdiagnosis produced by typical voltage fluctuations. As a result, the detection can enhance sensitivity. Second, the typical VU/THD system maintains VU along current THD simultaneously, but VU is more sensitive to disruption than current THD. Therefore, the voltage THD is maintained instead of the proposed approach. Moreover, the improved VU/THD has enhanced performance contrasted to other methods.

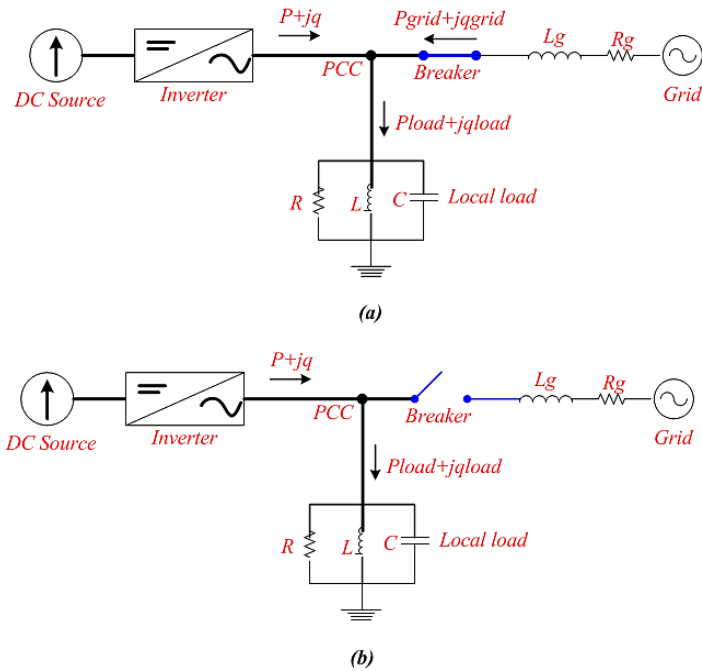

Figure 2: In both grid-linked and island-based operating modes, the general framework of a distributed inverter-based generation system is shown.

Mostly, the main grid loss affects a 3-phase voltage imbalance because the three-phase distributed generator unit can power several types of single-phase loads. Moreover, the load consumed along DG is matched; the voltage imbalance varies with network topology modification and disturbances among several controllers. In particular, VU can be denoted as

$$vu = \frac{v_{ns}}{v_{ps}} \times 100\% \quad (1).$$

Here, the magnitude of +ve with -ve series components of PCC voltage is denoted as VPS , VNS . Also, the VU deviation is expressed as

$$\Delta vu = \frac{vu_T - vu_{T-D}}{vu_{T-D}} \times 100\% \quad (2),$$

where at present moment the voltage unbalance is denoted as vu_T and the value of before fundamental cycle denotes vu_{T-D} , one fundamental cycle is denoted as d .

Normally, based on the pulse width modulation, behaviors of non-ideal switching of the power devices and the disturbance between several controllers, the harmonics are produced by inverters. The harmonic currents generated through the inverter may flow out into a lower impedance grid while the inverter works at the grid-connected mode to create only a less quantity of deformation at the point of common coupling voltage. But, the harmonic currents flow into the local loads when the grid disconnects, normally compared to the grid it has high impedance. Also, it generates high harmonics on point of common coupling voltage. The total harmonic distortion voltage is given as

$$thd = \sqrt{\sum_{H>1}^h v_H^2} / v_1 \times 100\% \quad (3).$$

Here, the rms value of harmonic components is denoted as V_h and the rms value of the fundamental component is denoted as V_1 . THD deviation is

$$\Delta thd = \frac{thd_T - thd_{T-D}}{thd_{T-D}} \times 100\% \quad (4),$$

where at present moment THD_t is the instant value and the value before at a fundamental cycle is denoted as THD_{t-d} .

The VU/THD mode deviation is utilized as the gateway detection criterion for $\Delta VU / \Delta THD$, and the inverter travels when it exceeds the VU or ΔTHD limit, which is highly sensitive. Moreover, the gateway system policy of this system has not yet been evaluated. Moreover, the detailed investigation is executed in subsection II-C, analysis based on the VU/THD system threshold being properly considered in the proposed hybrid system.

The disadvantage is it can cause troublesome travel subject to huge load shifting or non-linear load incorporation even when contrasted with distributed generator application, but it is suitable for hybrid mode acceptance based on the capability of superior detection.

3.2 Bilateral Reactive Power Variation

Generally, the Reactive Power Variation is the active model, this is easy to implement, and also does not establish any compatible events. It regulates the inverter to output enough reactive power. Several reactive power variation approaches were presented in the literature, and it has been demonstrated that the bilateral reaction force variation (BRPV) method can reduce NDZ with very little result in power quality. The intermediate BRPV modifies the range of output reaction force among the positive value Q_{dis} , the negative value $-Q_{dis}$ and 0. In Figure 3 while the distributed generator is linked with utility, the active with reactive power is consumed via the local load.

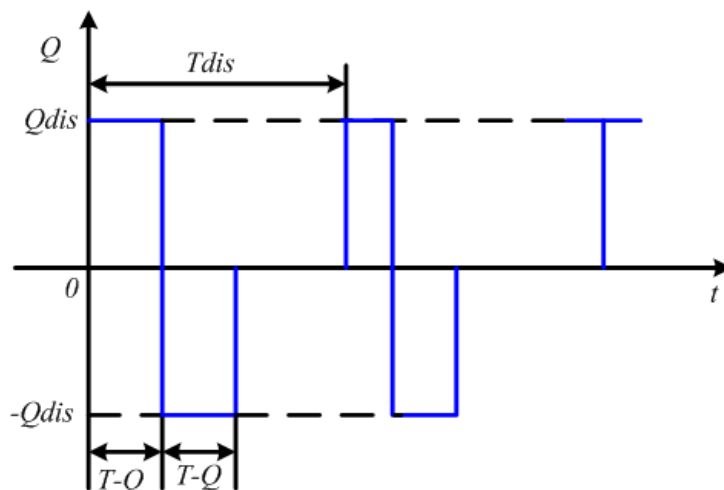

Figure 3: Schematic diagram of intermittent BRPV

$$P_{load} = P + P_{Grid} = 3 \frac{v_{pcc}^2}{r} \quad (5),$$

$$q_{Load} = q + q_{Grid} = 3v_{pcc}^2 \left(\frac{1}{2\pi Fl} - 2\pi Fc \right) \quad (6).$$

Here, the voltage and frequency of the PCC are denoted as V_{PCC} and f , the reactive with an active power output of the inverter is denoted as Q and P , and the inductance, capacitance, and resistance of the local load are denoted as L, C, R . The resonance frequency f_0 and quality factor Q_f are

$$F_0 = \frac{1}{2\pi\sqrt{lc}} \quad (7),$$

$$q_F = r\sqrt{\frac{c}{l}} \quad (8).$$

The relationship between the system frequency at grid-connected operation mode, then the RLC load characteristics are calculated by combining (5) and (6),

$$F = \frac{F_0}{2} \left[\sqrt{\left(\frac{q_{Load}}{q_F P_{Load}} \right)^2 + 4} - \frac{q_{Load}}{q_F P_{Load}} \right] \quad (9).$$

Generally, the frequency in the islanding condition is expressed as

$$F = \frac{F_0}{2} \left[\sqrt{\left(\frac{q}{q_F P} \right)^2 + 4} - \frac{q}{q_F P} \right] \quad (10).$$

Thus, the frequency after the island can be expelled by changing the range of the reaction force from the allowable range. Combining (9) and (10), the frequency of the island can thus be obtained.

$$F_{IS} = \frac{F}{4} \left[\sqrt{\left(\frac{q_{Load}}{q_F P_{Load}} \right)^2 + 4} + \frac{q_{Load}}{q_F P_{Load}} \right] \times \left[\sqrt{\left(\frac{q}{q_F P} \right)^2 + 4} - \frac{q}{q_F P} \right] \quad (11).$$

Assuming the range of frequency $[fmin, fmax]$, the NDZ can be measured from equation (11) and can be expressed as

$$q_F = \left(\frac{F_{Min}\sigma}{F} - \frac{F}{F_{Min}\sigma} \right) \leq \frac{q_{Load}/P}{P_{Load}/P} \leq q_F \left(\frac{F_{Max}\sigma}{F} - \frac{F}{F_{Max}\sigma} \right) \quad (12).$$

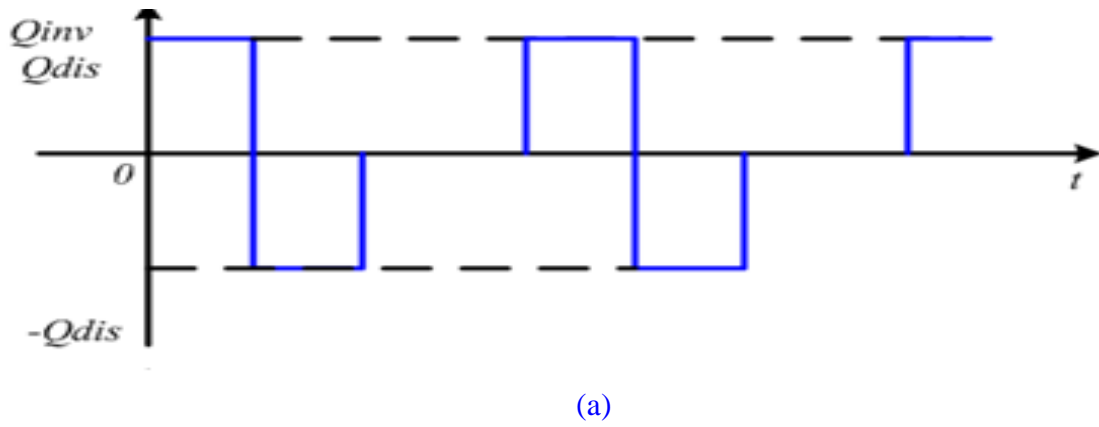

(a)

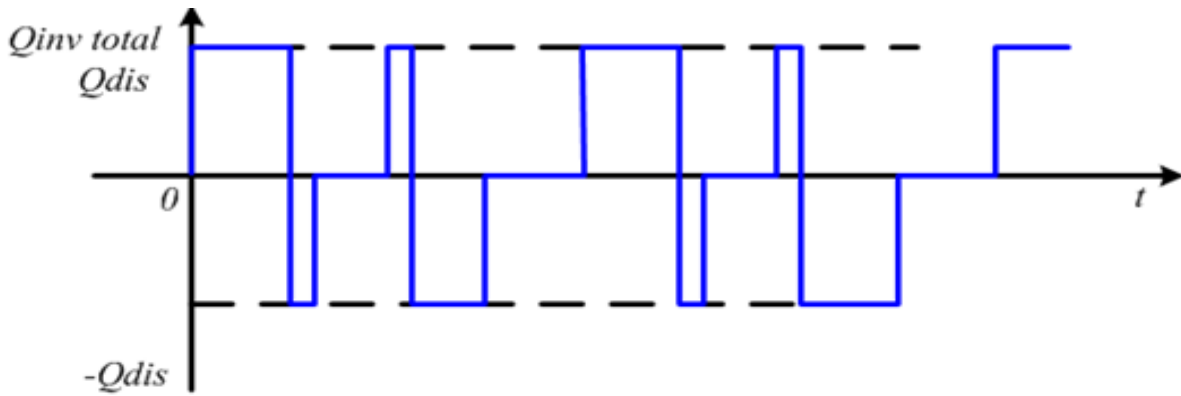

(b)

Figure 4: Counteraction design of BRPV in inverter scheme with (a) reactive power output of the inverter (b) total reactive power output of inverter

Here,

$$\sigma = \frac{1}{2} \left[\sqrt{\left(\frac{q}{q_{FP}} \right)^2 + 4} + \frac{q}{q_{FP}} \right] \quad (13).$$

Based on Equation (12), the NDZ of BRPV is derived in 2 components. If reactive power $Q = Q_{dis}$, then NDZ denotes $Z+Q$, if $Q = -Q_{dis}$ then NDZ represents $Z-Q$, the final NDZ scheme is an overlapping area among $Z+Q$ and $Z-Q$. To diminish the NDZ of BRPV, $Z+Q$ along $Z-Q$ could not overlap. By Equation (12), the amplitude variation Q_{dis} of reactive power is satisfied.

$$q_{Dis} > \frac{F_{Max} - F_{Min}}{\sqrt{F_{Max} F_{Min}}} q_{FP} \quad (14).$$

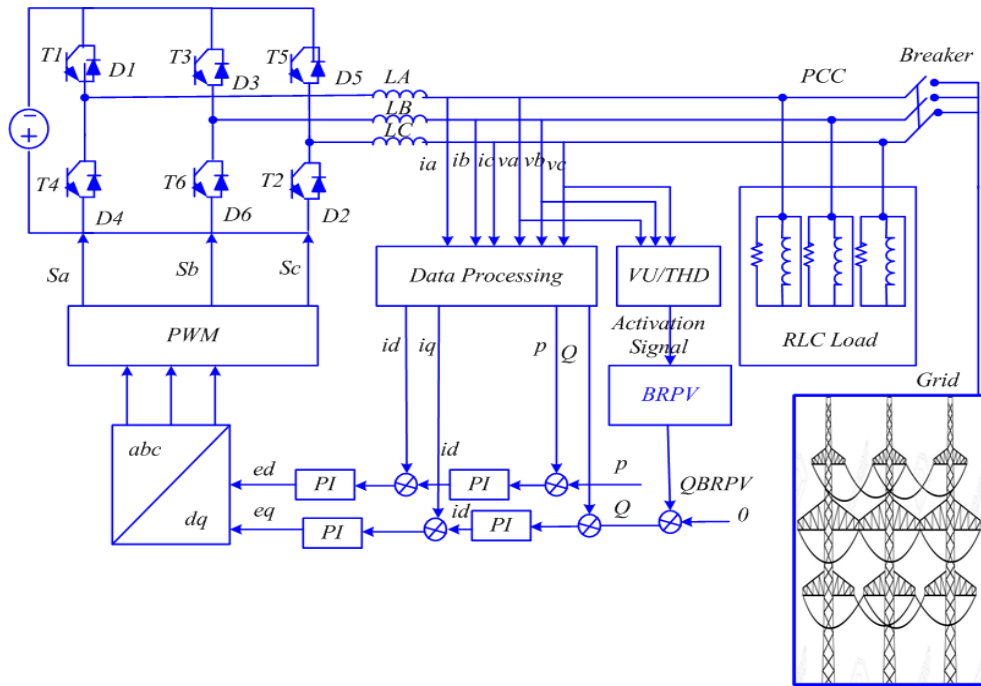

Figure 5: Block diagram of proposed approach at inverter control mode.

Therefore, the NDZ of BRPV is diminished through the design of the parameters correctly without presenting any compatible components, this is more suitable for inverters depending on DGs. Moreover, the BRPV system contains several disadvantages. The reaction of the intermediate PRPV is expressed in Figure 4, which results in a reduction in the output reaction force disturbance, resulting in detection failure. This issue is solved even if a hybrid system is adopted as the active model.

3.3 Hybrid Operation

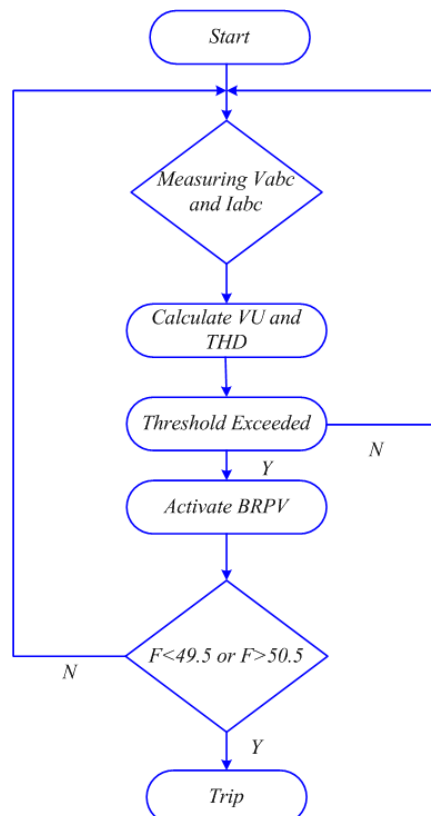

Figure 6: Flowchart of the proposed approach

The VU/THD, BRPV are appropriate to be utilized in the hybrid approach depending on the mentioned analysis. Furthermore, the inverter-based DG is contrasted together to get a satisfactory performance. Figure 5 depicts the block diagram of the proposed approach.

3.4 Operation Principle

Figure 6 depicts the structure of the proposed approach. Moreover, the point of common coupling voltage is examined constantly, and the deviation of VU along THD in 1 cycle is measured.

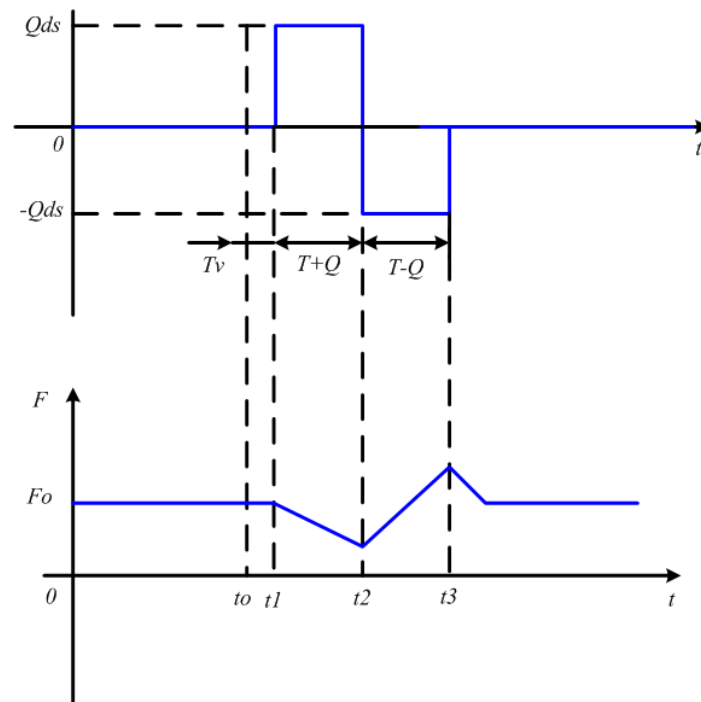

Figure 7: Description process of the proposed approach

When ΔVU or ΔTHD limit is presumed, the BRPV mode is operated. In the proposed hybrid mode, the BRPV system should change the range of output reaction power among $Qdis$ and $-Qdis$ as soon as it obtains the activation signal rather than working from time to time in the usual ways. Then, the frequency deviates the allowable range along approximately considered parameters if working in DG Islanding mode, and the inverter will shut down as a result.

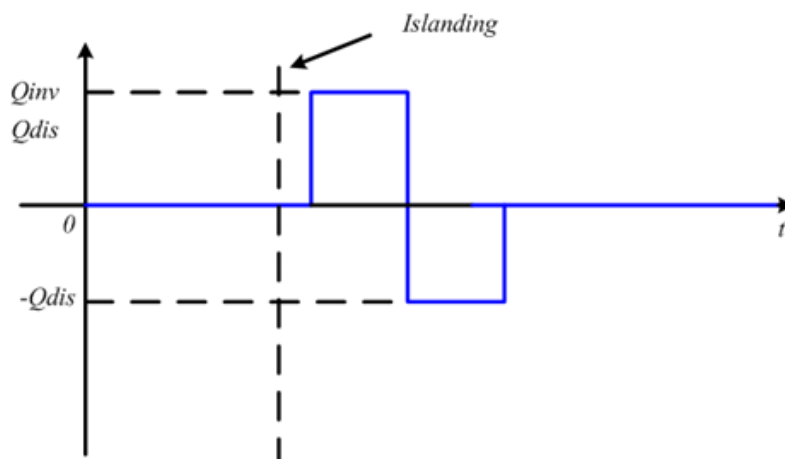

Figure 8: Synchronous operation in inverter

Figure 7 represents the process description of the proposed hybrid system. Here, BRPV is activated concurrently for modifying the output reaction force, then frequency exits the allowable area. The DG will stop immediately once the frequency limit is reached. Figure 8 represents the synchronous mode of multi-distributed generators. Here, the variations of reactive power are synchronized in both inverters, hence it is not counteraction among inverters.

Several local load functions, like larger load switch, and non-linear load incorporation generate VU/THD system to over current, resulting in the BRPV system being activated. Non-island bugs to the DG can also generate high voltage and reactive power variations, which can then lead to excessive input of the VU/THD system together with BRPV system activation. But, it is observed that island detection is ultimately determined through the frequency of the proposed hybrid system. In these cases, frequency performance is inappropriate since the frequency is global variance, and also does not depend upon local events that occur voltage or reactive power variance. Therefore, the proposed approach does not fail in such concerns.

Furthermore, the inverter is always connected to the network and the grid frequency is within the stated standards, the proposed method does not cause any problems.

- Concluding, the proposed approach consists of the following characters: The proposed method is DG. System frequency instead of tripping at the same time
- After the loss of the main grid, the VU/THD approach finds the islanding condition and the bilateral reactive power variation is carried out, hence the time of detection is less.
- The proposed hybrid method has no harmonic components and only has a suppressive effect on the power factor when the BRPV method is energized.
- Since the R BRPV system is activated by VU/THD system only when island conditions are suspected, the BRPV system can be coordinated with the signal of the trigger from the VU/THD system so that the hybrid system performs clearly in multi-inverter systems.

3.5 Parameter Design

The threshold structure of the VU/THD system could not be examined in depth until now. Therefore, for the first time, this paper examines the portal design due to the equivalent round strategy.

The passive model threshold in the hybrid approach is

$$\Delta v_u > 50\% \text{ or } \Delta t_{hd} > 100\% \quad (15)$$

To the analysis of VU diffraction, when remote from the phase, there are 3 system conditions: (i) 3-phase distributed generator unit powers several types of single-phase loads, it makes ΔVU greater than 50%. (ii) 3-phase distributed generator unit powers the similar type of single-phase loads, but the power variance is huge, here, the frequency goes beyond the allowable range, (iii) critical condition to island detection is the distributed generator unit powers the similar types of single-phase loads, also the power variance is smaller.

Figure 8 represents the equivalent circuit diagram of the phase-connected inverter. The inverter is denoted by Norton equivalent circuit, in which the current source is parallel to the inverter output resistance Z_0 . And is expressed by the equivalent circuit of the phase winding, where the best voltage source is in the ug and phase resistance $Z_g = R_g + jX_g$ series. And the inverter can distort the output current

$$I_{inv} = I_{PS} + I_{ns} \quad (16).$$

Here, the +ve series and -ve current series are represented as i_{PS} and i_{NS} , so the -ve series PCC voltage under grid-connected mode is

$$v_{ns} = \frac{z_G z_{Load}}{z_G + z_{Load}} I_{ns} \quad (17).$$

The current is deemed as stable at the instant of islanding happens. Thus, the -ve series voltage of PCC after islanding is

$$v_{ns} = z_{Load} I_{ns} \quad (18)$$

If the power mismatch is smaller, the deviation of +ve series voltage Δv_{PS} is smaller than that of the v_{PS} .

$$\Delta vu = \frac{|v_{ns}|/|v_{ps}| - |v_{ns}|/|v_{ps}|}{|v_{ns}|/|v_{ps}|} \approx \frac{|v_{ns}| - |v_{ns}|}{|v_{ns}|} = \frac{|z_G + z_{Load}|}{|z_G|} - 1 \quad (19).$$

Further analysis is carried out to clear the influence of grid impedance. Inspect, the short-circuit ratio (SCR) is expressed as

$$SCR = \frac{v_T^2}{|z_G| P_{Rated}} \quad (20)$$

V_t and P_{rated} indicate the rated ac line to line voltage with inverter power. Assuming that the distributed generator operates at a unity power factor, the relationship between rated power and load impedance is as follows:

$$|z_{Load}| = |z_G| \cdot SCR \quad (21)$$

Assuming $R_g = n \cdot X_g$, (19) can be presented as

$$\Delta vu = \frac{\sqrt{(r_G + r_{Load})^2 + x_G^2}}{\sqrt{r_G^2 + x_G^2}} - 1 = \sqrt{1 + SCR^2 + \frac{2}{\sqrt{N^2 + 1}}} \cdot SCR - 1 \quad (22)$$

While ΔVU threshold is set to be 0.5, this detection method is exhibited as

$$\sqrt{1 + scr^2 + \frac{2N}{\sqrt{N^2 + 1}}.scr - 1} > 0.5 \quad (23).$$

If $N > 0$ (24) is correct, it obtained as $SCR > 1.12$. While n denotes known value at the practical stage, the SCR value may additionally minimize. At IEEE. 1547-2003, the grid-connected inverter is evaluated to work stable in $SCR > 20$, weak phase on HVDC scheme exhibits $SCR < 3$ in IEEE Std. 1204-1997 [34]. Therefore, the threshold structure of $gVU > 50\%$ is adequate to detect the island under different phase conditions.

It has to do with local load circumstances and harmonic deviation. After islanding, the THD is larger than 100% if the local load is resistive or the non-linear load is proportionally large. The voltage harmonic does not exceed the threshold when the capacitive load is comparably higher or when the local load impedance is not higher than the grid impedance. Furthermore, because the VU method can detect islands in a variety of grid states, the THD can be used to improve detection reliability in the VU/THD mode. The VU/THD threshold setting is appropriate in the suggested approach to pre-identify the island stages.

To BRPV mode, it can remove NDZ. When set to Qf 2.5 of local load based on IEEE Std. 929, IEEE std. 1547, f_{max} , f_{min} are specified in the 50 Hz system as 50.5 and 49.5 Hz,

$$q_{Dis} > 5\% p \quad (24)$$

The amplitude of reactive power perturbation at Bilateral Reactive Power Variation is represented as,

$$q_{Dis} = 5\% p \quad (25)$$

In the non-detection zone along the amplitude $Q_{dis} = 5\% P$ at BRPV, there is a lack of overlap among 2 portions, here the output reactive power equals Q_{dis} , $-Q_{dis}$ respectively, i.e non-detection zone is rejected.

Positive amplitude Q_{dis} and negative amplitude $-Q_{dis}$ have been chosen as equal perturbation times $T+Q$ with $T-Q$ of reactive power.

$$t_{+q} = t_{-q} = t_q \quad (26)$$

$$t_q = 150MS \quad (27)$$

Here, the variation time is denoted as TQ . Based on the analysis the system transient response is evaluated. During time constant of first-order filter $\tau = 0.001$, proportional integral controller parameters $Kp_{PLL} = 10$, $Ki_{PLL} = 2000$, the transient response time is computed as $t_s \approx 70.4$ ms.

4 Result and Discussion

A novel hybrid approach is proposed for the islanding detection of Distributed Generation units. The proposed hybrid approach is the consolidation of an active and passive model, in which,

the BRPV method is used as a selected active model, and VU/THD is used as a passive model. In this proposal, active and passive models are utilized to detect the islanding of the DG system. By then, the performance of the proposed technique is activated in MATLAB/Simulink, then the performance is analyzed under three case study conditions: Before Islanding, During Islanding, and After Islanding condition.

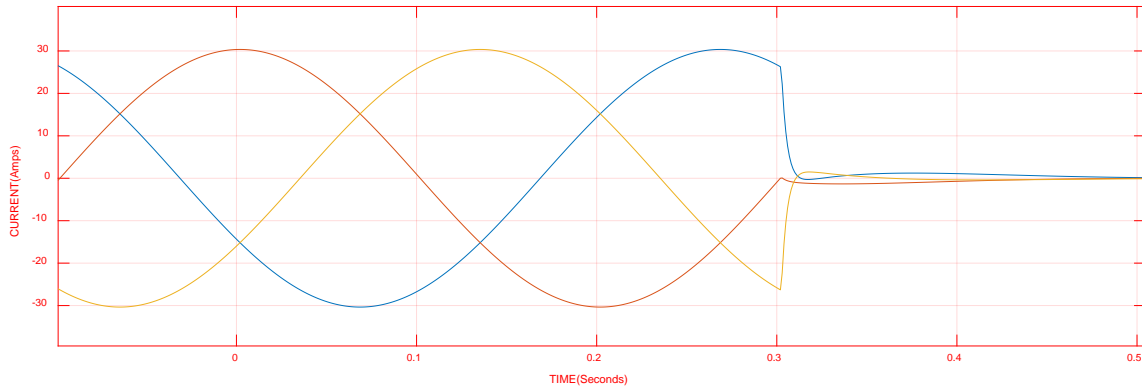

Figure 9(a): Grid Current

Grid current is depicted in Figure9(a). The grid current flows from -30A to 30A from 0 to 0.3sec, after which it remains zero.

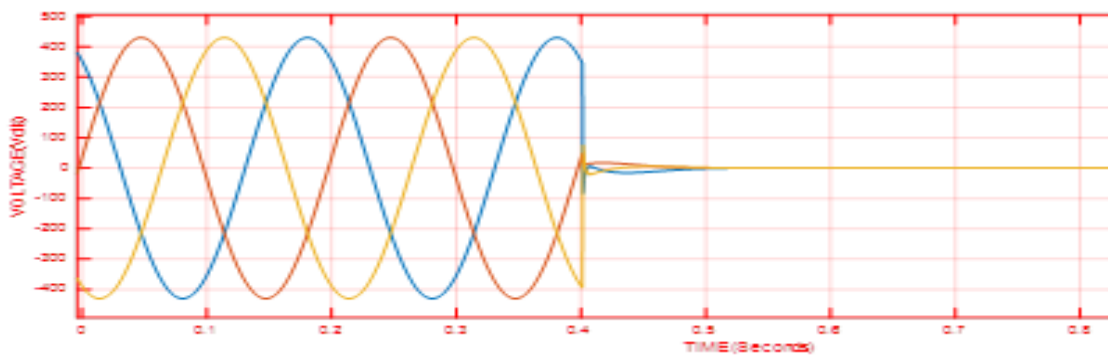
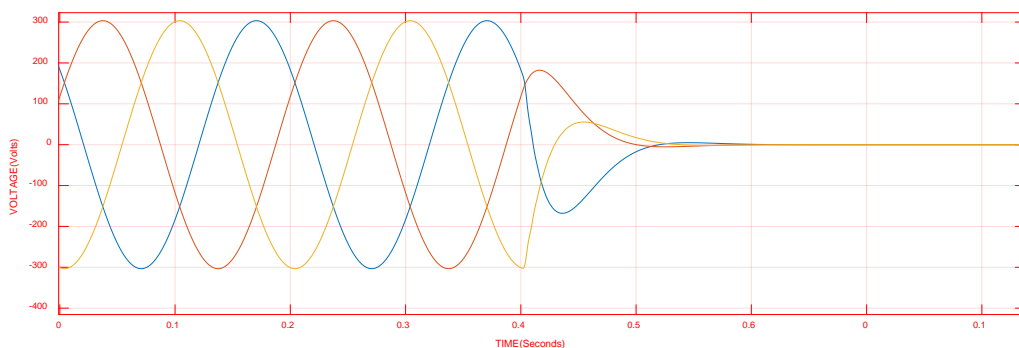
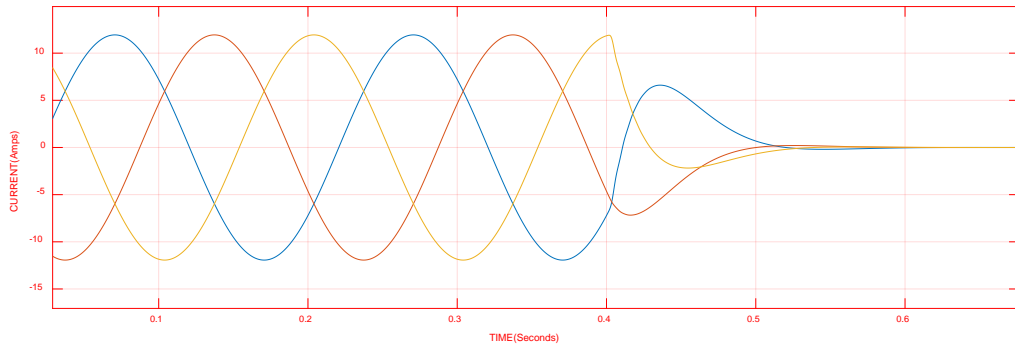

Figure 9(b): Grid Voltage

Grid voltage is depicted in Figure 9(b). The grid voltage flows from -400V to 400V between 0 and 0.4sec, then the interruption occurs at 0.4sec, and the grid voltage remains zero.



(a)



(b)

Figure 10: (a) DG Voltage, (b) DG Current

The islanding of DG voltage is seen in Figure 10(a). The DG voltage flows from -300V to 300V over a time period of 0 to 0.45sec, then becomes zero after 0.45sec.

Figure 10(b) depicts the islanding of the DG current. The DG current runs from -11A to 11A over a period of 0 to 0.45sec, then becomes zero after 0.45sec.

The islanding of load current is depicted in Figure 11(a). The load current runs from -20A to 20A over a time span of 0 to 0.45sec, then becomes zero after 0.45sec.

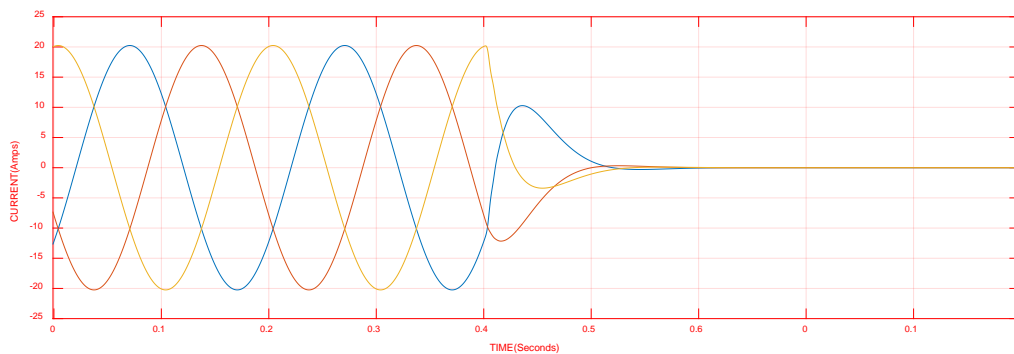

(a)

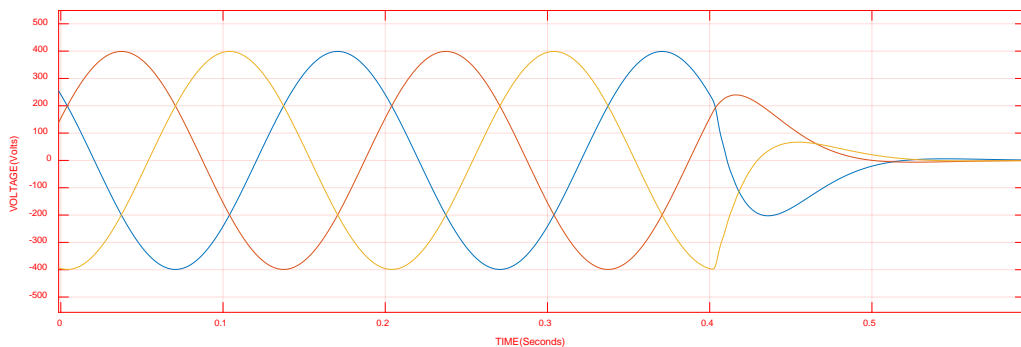

Figure 11: (a) Load Current, (b) Load Voltage.

The islanding of load voltage is shown in Figure 11(b). The load voltage changes from -400V to 400V over a time period of 0 to 0.45sec, after which the DG voltage drops to zero.

5 Conclusion

The proposed method is the consolidation of the active and passive model, in which, the BRPV method is used as a selected active model, and VU/THD is used as a passive model. Integrating these models, it minimizes the limitation of each model, at the same time incorporating its advantages. In particular, the BRPV method is induced only if island status is suspected by the VU/THD method. By doing so, the performance of islanding detection is substantially enhanced without lessening the power quality. Moreover, this proposal modifies the typical VU/THD method for realizing rapid with accurate detection, also the principle of threshold setting is examined on the basis of equivalent circuit strategy. By then, the performance of the proposed technique is activated in MATLAB/Simulink site.

6 Availability of Data and Material

Data can be made available by contacting the corresponding author.

7 References

- Zeineldin HH, Conti S. Sandia frequency shift parameter selection for multi-inverter systems to eliminate non-detection zone. *IET Renewable Power Generation*. 2011 Mar 1;5(2):175-83.
- Alaboudy AH, Zeineldin HH. Islanding detection for inverter-based DG coupled with frequency-dependent static loads. *IEEE transactions on power delivery*. 2010 Nov 18;26(2):1053-63.
- Lopes LA, Sun H. Performance assessment of active frequency drifting islanding detection methods. *IEEE Transactions on Energy Conversion*. 2006 Feb 21;21(1):171-80.
- Tsukamoto O, Okayasu T, Yamagishi K. Study on islanding of dispersed photovoltaic power systems connected to a utility power grid. *Solar energy*. 2001 Jan 1;70(6):505-11.
- Zeineldin HH, El-Saadany EF, Salama MM. Impact of DG interface control on islanding detection and nondetection zones. *IEEE transactions on power delivery*. 2006 Jun 26;21(3):1515-23.
- Zeineldin HH, Kirtley JL. A simple technique for islanding detection with negligible nondetection zone. *IEEE Transactions on Power Delivery*. 2009 Mar 16;24(2):779-86.
- Zeineldin HH, Kirtley JL. Performance of the OVP/UDP and OFP/UDP method with voltage and frequency dependent loads. *IEEE Transactions on Power Delivery*. 2009 Mar 21;24(2):772-8.
- Yu B, Matsui M, So J, Yu G. A high power quality anti-islanding method using effective power variation. *Solar Energy*. 2008 Apr 1;82(4):368-78.
- Vieira JC, Freitas W, Huang Z, Xu W, Morelato A. Formulas for predicting the dynamic performance of ROCOF relays for embedded generation applications. *IEE Proceedings-Generation, Transmission and Distribution*. 2006 Jul 1;153(4):399-406.
- Usta O, Bayrak M, Redfern MA. A new digital relay for generator protection against asymmetrical faults. *IEEE transactions on power delivery*. 2002 Aug 7;17(1):54-9.
- Jang SI, Kim KH. An islanding detection method for distributed generations using voltage unbalance and total harmonic distortion of current. *IEEE transactions on power delivery*. 2004 Mar 30;19(2):745-52.
- Choudhry MA, Khan H. Power loss reduction in radial distribution system with multiple distributed energy resources through efficient islanding detection. *Energy*. 2010 Dec 1;35(12):4843-61.

Akhlaghi S, Meshginkelk H, Akhlaghi A, Ghadimi AA. A novel hybrid islanding detection method for inverter-based distributed generation based on frequency drift. Australian Journal of Electrical and Electronics Engineering. 2014 Jan 1;11(2):161-74.

Menon V, Nehrir MH. A hybrid islanding detection technique using voltage unbalance and frequency set point. IEEE Transactions on Power Systems. 2007 Jan 29;22(1):442-8.

Chang WY. An Active Islanding Detection Method for Grid-Connected Renewable Energy Generation System. In Applied Mechanics and Materials 2014 (Vol. 479, pp. 580-584). Trans Tech Publications Ltd.

Mahat P, Chen Z, Bak-Jensen B. Underfrequency load shedding for an islanded distribution system with distributed generators. IEEE transactions on Power Delivery. 2009 Nov 17;25(2):911-8.

Zeineldin HH, Salama MM. Impact of load frequency dependence on the NDZ and performance of the SFS islanding detection method. IEEE Transactions on Industrial Electronics. 2009 Oct 6;58(1):139-46.

Khabbazi A, Atashpaz-Gargari E, Lucas C. Imperialist competitive algorithm for minimum bit error rate beamforming. International Journal of Bio-Inspired Computation. 2009 Jan 1;1(1-2):125-33.



Besta Hariprasad received his B.Tech degree and M.Tech degree in Electrical and Electronics Engineering. Currently, he is a Ph.D. Scholar in Jawaharlal Nehru Technical University Anantapur, Electrical and Electronics Engineering, and his area of interest includes power Quality Improvements and smart grids.



Dr.P Bharath Kumar received a B. Tech degree in Instrumentation and Control Engineering from JNTU Hyderabad, AN M. Tech degree in Control Systems from JNTUA Anantapur and a Ph.D. in Control Systems from JNTUA. He is currently working as Assistant Professor (Adhoc) in EEE Department, JNTUA CEA. His research interests include Controllers design using AI techniques, nonlinear control and Robust Control.



Dr. P. Sujatha is a Professor in the Department of Electrical Engineering, J.N.T.U. A. College of Engineering, Ananthapuramu, Andhra Pradesh, India. She got her B. Tech degree and M. Tech Degree with specialization in Electrical Power Systems & Ph.D from J.N.T.U.A, Anantapur, Andhra Pradesh, India. Her areas of interest include Reliability Engineering with an emphasis to Power Systems and Real-time Energy Management.



Dr.Goturu Sreenivasan is a Professor in the Department of Electrical Engineering, PVKK Institute of Technology, Ananthapuramu, Andhra Pradesh, India. He completed his B. Tech degree and M. Tech Degree with specialization in Electrical Power Systems from J.N.T.U.A, Anantapur, Andhra Pradesh, India. & Ph. D in 2013 from J.N.T.U., Kakinada, Andhra Pradesh, India. His areas of interest is Applications of GA and PSO to Power System Operation and Control.
